

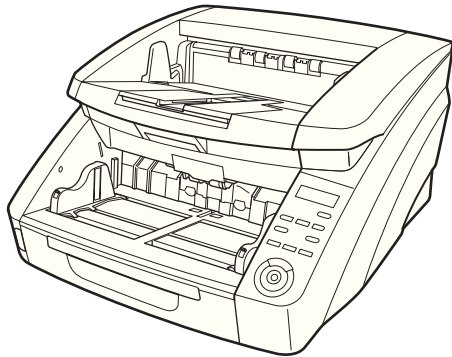

imageFORMULA

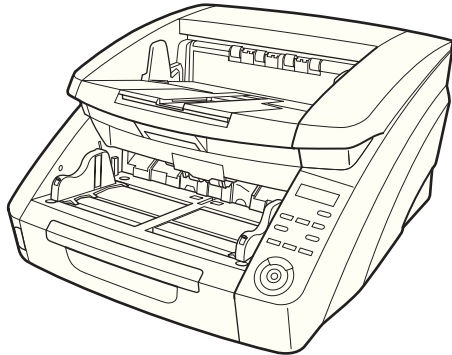

DR-9050C/DR-7550C



DR-6050C

DR-9050C
DR-7550C
DR-6050C
User Manual

Please read this manual before using the scanner.
After you finish reading this manual, keep it in a safe place for future reference.

FCC REGULATIONS (For 120 V model)

Document Scanner:

- DR-6050C: Model M11070
- DR-7550C: Model M11069
- DR-9050C: Model M11068

This device complies with Part 15 of the FCC Rules.

Operation is subject to the following two conditions: (1) This device may not cause harmful interference, and (2) this device must accept any interference received, including interference that may cause undesired operation.

Note: This equipment has been tested and found to comply with the limits for a Class B digital device, pursuant to Part 15 of the FCC Rules. These limits are designed to provide reasonable protection against harmful interference in a residential installation. This equipment generates, uses, and can radiate radio frequency energy and, if not installed and used in accordance with the instructions, may cause harmful interference to radio communications. However, there is no guarantee that interference will not occur in a particular installation. If this equipment does cause harmful interference to radio or television reception, which can be determined by turning the equipment off and on, the user is encouraged to try to correct the interference by one or more of the following measures:

- Reorient or relocate the receiving antenna.
- Increase the separation between the equipment and receiver.
- Connect the equipment into an outlet on a circuit different from that to which the receiver is connected.
- Consult the dealer or an experienced radio/TV technician for help.

Use of shielded cable is required to comply with class B limits in Subpart B of Part 15 of FCC Rules.

Do not make any changes or modifications to the equipment unless otherwise specified in the manual. If such changes or modifications should be made, you could be required to stop operation of the equipment.

Canon U.S.A. Inc.

One Canon Plaza, Lake Success NY 11042, U.S.A.

Tel. No. (516)328-5000

RADIO INTERFERENCE REGULATIONS (For 120 V models)

This digital apparatus does not exceed the Class B limits for radio noise emissions from digital apparatus as set out in the Interference-causing equipment standard entitled “Digital Apparatus”, ICES-003 of the Industry Canada.

RÈGLEMENT SUR LE BROUILLAGE RADIOÉLECTRIQUE (For 120 V models)

Cet appareil numérique respecte les limites de bruits radioélectriques applicables aux appareils numériques de Classe B prescrites dans la norme sur le matériel brouilleur: “Appareils Numériques”, NMB-003 édictée par l’Industrie Canada.

International ENERGY STAR® Office Equipment Program



As an ENERGY STAR® Partner, Canon Electronics Inc. has determined that this machine meets the ENERGY STAR® Program guidelines for energy efficiency.

The International ENERGY STAR® Office Equipment Program is an international program that promotes energy saving through the use of computers and other office equipment. The program backs the development and dissemination of products with functions that effectively reduce energy consumption. It is an open system in which business proprietors can participate voluntarily. The targeted products are office equipment, such as computers, displays, printers, facsimiles, copiers, and scanners. The standards and logos are uniform among participating nations.

European Union (and EEA) only.



This symbol indicates that this product is not to be disposed of with your household waste, according to the WEEE Directive (2002/96/EC) and your national law. This product should be handed over to a designated collection point, e.g., on an authorized one-for-one basis when you buy a new similar product or to an authorized collection site for recycling waste electrical and electronic equipment (EEE). Improper handling of this type of waste could have a possible negative impact on the environment and human health due to potentially hazardous substances that are generally associated with EEE. At the same time, your cooperation in the correct disposal of this product will contribute to the effective usage of natural resources. For more information about where you can drop off your waste equipment for recycling, please contact your local city office, waste authority, approved WEEE scheme or your household waste disposal service. For more information regarding return and recycling of WEEE products, please visit www.canon-europe.com/environment. (EEA: Norway, Iceland and Liechtenstein)

Für EMVG

Dieses Produkt ist zum Gebrauch im Wohnbereich, Geschäfts-und Gewerbebereich sowie in Kleinbetrieben vorgesehen.

Für 3. GPSGV

“Maschinenlärminformations-Verordnung 3. GPSGV: Der höchste Schalldruckpegel beträgt 70 dB(A) oder weniger gemäß EN ISO 7779”

Model Names

The following names may be provided for the safety regulations in each sales region of the Document Scanner.
DR-6050C: Model M11070
DR-7550C: Model M11069
DR-9050C: Model M11068

Trademarks

- Canon and the Canon logo are registered trademarks of Canon Inc. in the United States and may also be trademarks or registered trademarks in other countries.
- imageFORMULA is a trademark of Canon Electronics Inc.
- Microsoft and Windows are either registered trademarks or trademarks of Microsoft Corporation in the United States and other countries.
- Adobe, Acrobat, and Adobe Reader are registered trademarks or trademarks of Adobe Systems Incorporated in the United States and other countries.
- ISISTM is a trademark of EMC Corporation in the United States.
- Other product and company names herein are, or may be, the trademarks of their respective owners.

Copyright

Copyright 2009 by Canon Electronics Inc. All rights reserved. No part of this publication may be reproduced or transmitted in any form or by any means, electronic or mechanical, including photocopying and recording, or by any information storage or retrieval system without the prior written permission of Canon Electronics Inc.

Disclaimers

The information in this document is subject to change without notice.

CANON ELECTRONICS INC. MAKES NO WARRANTY OF ANY KIND WITH REGARD TO THIS MATERIAL, EITHER EXPRESS OR IMPLIED, EXCEPT AS PROVIDED HERE IN, INCLUDING WITHOUT LIMITATION, THEREOF, WARRANTIES AS TO MARKETABILITY, MERCHANTABILITY, FITNESS FOR A PARTICULAR PURPOSE OF USE OR NON-INFRINGEMENT. CANON ELECTRONICS INC. SHALL NOT BE LIABLE FOR ANY DIRECT, INCIDENTAL, OR CONSEQUENTIAL DAMAGES OF ANY NATURE, OR LOSSES OR EXPENSES RESULTING FROM THE USE OF THIS MATERIAL.

Preface

Thank you for purchasing the Canon imageFORMULA DR-6050C/DR-7550C/DR-9050C Document Scanner. Please read this and the following manuals thoroughly before using the scanner to become acquainted with its capabilities and make the most of its many functions.

After reading the manuals, store them in a safe place for future reference.

Manuals for the Scanner

The documentation for the scanner consists of the *Easy Start Guide* and the *Reference Guide* (supplied with the scanner), the *User Manual* (this manual), and the *CapturePerfect 3.0 Operation Guide*, which are provided in electronic form and registered in the menu during software installation.

Easy Start Guide

This manual describes the procedures for setting up the scanner for use. Please follow the procedures in the *Easy Start Guide* to set up the scanner.

Reference Guide

This manual consists of the basic scanner operating instructions extracted from the *User Manual*.

User Manual (This Manual)

This manual consists of two sections: Hardware and Software.

The Hardware section provides general information about the scanner operational settings, maintenance, and troubleshooting.

The Software section describes how to use the ISIS/TWAIN driver with the scanner, and how to set up job registration tools.

CapturePerfect 3.0 Operation Guide (Electronic Manual)

This is the operation guide for CapturePerfect 3.0, the Canon document scanner application program.

Hint

- The User Manual and the CapturePerfect 3.0 document files are installed in the following locations during software installation.

User Manual

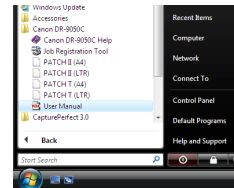

CapturePerfect 3.0 Operation Guide

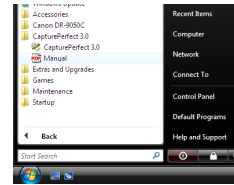

- Electronic versions of all manuals are available for viewing from the Setup CD. (See p. 2-5.)

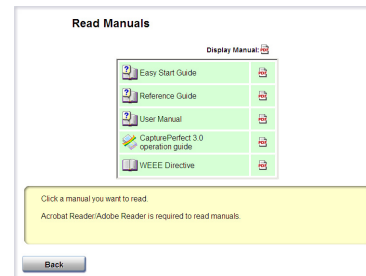

Symbols Used in This Manual

The following symbols are used in this manual to explain procedures, restrictions, handling precautions, and instructions that should be observed for safety.

WARNING

Indicates a warning concerning operations that may lead to death or injury to persons if not performed correctly. To use the scanner safely, always pay attention to these warnings.

CAUTION

Indicates a caution concerning operations that may lead to injury to persons, or damage to property if not performed correctly. To use the scanner safely, always pay attention to these cautions.

IMPORTANT

Indicates operational requirements and restrictions. Make sure that you read these items carefully to operate the scanner correctly, and avoid damage to the scanner.

Hint

Indicates a clarification of an operation, or contains additional explanations for a procedure. Reading these notes is highly recommended.

How This Manual is Organized

This manual consists of the following chapters.

■ **Hardware**

Chapter 1 Before You Start Using the Scanner

Provides an overview of the scanner

Chapter 2 Setup

Describes the operating environment and how to connect to a PC

Chapter 3 Basic Operation

Describes the basic uses of the scanner

Chapter 4 Other Functions

Describes the User Mode and other functions

Chapter 5 Maintenance

Describes routine cleaning and roller replacement

Chapter 6 Practical Examples

Describes displayed messages and troubleshooting solutions

Chapter 7 Appendix

Provides a list of specifications and support information

■ **Software**

Chapter 8 ISIS/TWAIN Driver Settings

Describes the settings for the ISIS/TWAIN driver

Chapter 9 Job Registration Tool Settings

Describes the settings for the Job Registration Tool

Chapter 10 Practical Examples

Provides information for reference when making software settings

User Manual

Hardware

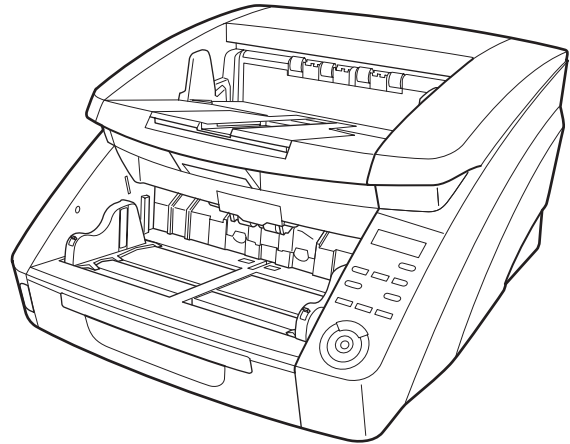

Please read this manual before using the scanner.
After you finish reading this manual, keep it in a safe place
for future reference.

Table of Contents

Preface	iii
Manuals for the Scanner	iii
Symbols Used in This Manual	iv
How This Manual is Organized.....	iv
Chapter 1 Before You Start Using the Scanner	
1. Important Safety Instructions.....	1-2
Installation Location.....	1-2
Power	1-2
Moving the Scanner.....	1-3
Handling	1-3
Disposal.....	1-5
2. Features	1-6
3. Names and Functions of Parts	1-10
Front View, Feeder Inlet, and Eject Outlet.....	1-10
Rear View.....	1-11
Control Panel.....	1-12
Chapter 2 Setup	
1. Setup Procedures.....	2-2
2. Installation Requirements.....	2-3
3. Software Installation	2-4
About the Setup Menu.....	2-4
4. Connecting the Scanner to the Computer	2-6
Interface Connector Locations.....	2-6
Connecting the Scanner to the Computer	2-6
5. Turning the Power ON (Scanner Recognition).....	2-9
About the Power Switch	2-9
Scanner Recognition	2-9
Chapter 3 Basic Operation	
1. Turning the Power ON and OFF	3-2
About the Power Switch	3-2
2. Documents	3-3
Acceptable Documents.....	3-3
3. Document Feed and Eject Trays.....	3-6
Preparing the Document Feed Tray	3-6
Adjusting the Document Guides	3-8
Preparing the Document Eject Tray	3-10
4. Document Feeding Methods	3-11
Selecting the Document Feeding Method	3-11
5. Scanning	3-14
About the Job Function.....	3-14
CapturePerfect 3.0	3-15
6. Using Patchcode Sheets (Option).....	3-20
About Patchcode Sheets	3-20
How to Use Patchcode Sheets.....	3-21
7. Clearing a Paper Jam or Double Feed	
Error	3-23
Paper Jam Handling	3-23
Handling a Double Feed.....	3-24
Chapter 4 Other Functions	
1. Other Functions and Settings.....	4-2
2. Function Description	4-4
3. User Mode.....	4-8
User Mode Operating Procedure.....	4-8
4. User Mode Functions	4-10
Chapter 5 Maintenance	
1. Regular Maintenance	5-2
Cleaning the Scanner	5-2
Cleaning the Sensors	5-2
Cleaning the Scanning Glass and Rollers	5-3
Power Outlet.....	5-4
2. Replacing the Transport Rollers.....	5-5
Roller Replacement Cycle	5-5
Checking and Resetting the Page Counter	5-5
Removing and Reinstalling the Rollers.....	5-7

3. Imprinter Ink Cartridge Replacement and	
Cleaning	5-13
About the Imprinter	5-13
Replacing Ink Cartridges	5-13
Specifying the Printing Position	5-15
Cleaning the Imprinter	5-16
Imprinter Testing.....	5-17

Chapter 6 Practical Examples

1. Messages	6-2
Status Display.....	6-2
Error Messages	6-3
2. Troubleshooting.....	6-5
Trouble Categories	6-5
Problem and Solution	6-5
3. Uninstalling the Software.....	6-9
Uninstalling the ISIS/TWAIN Driver	6-9

Chapter 7 Appendix

1. Specifications	7-2
Unit Specifications	7-2
Options	7-3
Consumables.....	7-3
External Dimensions.....	7-4
2. Option Specifications.....	7-5
Barcode Specifications	7-5
Imprinter Specifications	7-6
3. Index.....	7-7

Chapter 1 Before You Start Using the Scanner

1. Important Safety Instructions	1-2
Installation Location	1-2
Power	1-2
Moving the Scanner	1-3
Handling	1-3
Disposal	1-5
2. Features.....	1-6
3. Names and Functions of Parts	1-10
Front View, Feeder Inlet, and Eject Outlet	1-10
Rear View.....	1-11
Control Panel	1-12

1. Important Safety Instructions

To ensure the safe operation of this scanner, be sure to read the safety warnings and precautions described below.

Installation Location

The performance of this scanner is affected by the environment in which it is installed. Make sure that the location where the scanner is installed meets the following environmental requirements.

- Provide adequate space around the scanner for operation, maintenance, and ventilation.

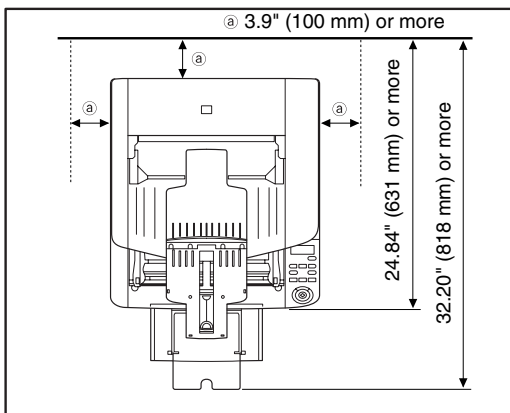

- Avoid installing the machine in direct sunlight. If this is unavoidable, use curtains to shade the scanner.
- Avoid locations where a considerable amount of dust accumulates.
- Avoid warm or humid locations, such as in the vicinity of a water faucet, water heater, or humidifier, and avoid locations where the fumes from ammonia, paint thinner, or other volatile chemicals may be present.

- Avoid locations that are subject to vibration.
- Avoid exposing the scanner to rapid changes in temperature. If the room in which the scanner is installed is cold but rapidly heated, water droplets (condensation) may form inside the scanner. This may result in a noticeable degradation in scanning quality.

The following conditions are recommended for optimal scanning quality:

Room temperature: 10 °C to 32.5 °C (50 °F to 90.5 °F)

Humidity: 20% to 80% RH

- Avoid installing the scanner near equipment that generates a magnetic field (e.g. speakers, televisions, or radios).

Power

- Connect only to a power outlet of the rated voltage and power supply frequency (either 120 V, 60 Hz or 220-240 V, 50/60 Hz, depending on your region).
- Do not use the scanner with a power supply that is not rated for the specified voltage. Doing so might cause fire or electric shock.
- Do not connect other electrical equipment to the same power outlet to which the scanner is connected. Also, when using an extension cord, make sure that the extension cord is rated for the current requirements of the scanner.
- The power cord may become damaged if it is often stepped on or if heavy objects are placed on it. Continued use of a damaged power cord can lead to an accident, such as a fire or electrical shock.

- Do not use the power cord while it is coiled.
- Do not pull directly on the power cord. When disconnecting the power cord, grasp the plug and remove it from the outlet.
- Keep the area around the power plug clear of objects so that the power cord can be disconnected easily in an emergency.
- If you have any questions regarding the power supply, contact your local authorized Canon dealer or service representative for further information.

Moving the Scanner

- The scanner weighs about 50 lbs (22.5 kg). To lift or move the scanner, always use two people, one on each side. Never attempt to lift the scanner by yourself. You could drop the scanner or pinch your fingers, resulting in personal injury or damage to the scanner. Remember to be extra careful when moving it.

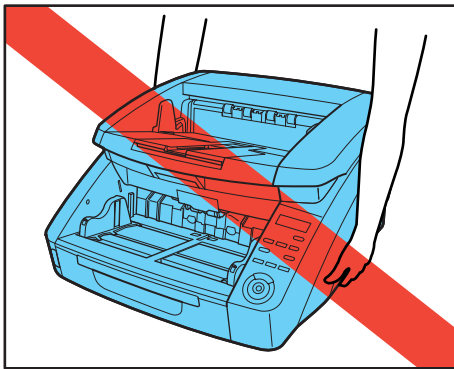

- Make sure to disconnect the interface cable and power cord when moving the scanner. If the scanner is carried with these items connected, the plugs and connectors may be damaged or cause the scanner to fall and result in personal injury or damage to the scanner.

Handling

WARNING

Note the following precautions whenever using the scanner. Failure to do so may result in a fire or electric shock.

- Never use alcohol, benzene, paint thinner, aerosol sprays, or any other highly flammable substance near the scanner.
- Do not cut, damage, or modify the power cord. Do not place heavy objects on the power cord, and do not pull or excessively bend the power cord.
- Never connect the power cord when your hands are wet.
- Do not connect the scanner to a multiplug power strip.
- Do not knot or coil the power cord, as this may result in a fire or electric shock. When connecting the power cord, make sure that the power plug is securely and completely inserted into the power outlet.
- To use a reel-type extension cord, unwind all of the cord from the reel. Long-term operation with the cord wound on the reel may cause the cord to overheat and could cause a fire.
- Do not use power cords other than the power cord provided with this scanner.

- Never try to take the scanner apart or modify it in any way, as this is dangerous and may lead to a fire or electric shock.
- Do not use flammable aerosol sprays products near the scanner.
- When cleaning the scanner, turn the power switch OFF and disconnect the power plug from the power supply.
- Clean the scanner using a slightly dampened cloth which has been well wrung out. Never use alcohol, benzene, paint thinner, or any other flammable substances.
- If the scanner makes strange noises, or gives off smoke, heat, or strange odors, or the scanner does not function or other abnormalities occur when you use the scanner, immediately turn the power switch OFF, and disconnect the power plug from the power outlet. Then, contact your local authorized Canon dealer or service representative for further information.
- Do not drop the scanner, or subject it to impact or strong shock. Should the scanner ever become damaged, immediately turn the power switch OFF, and disconnect the power plug from the power outlet. Then, contact your local authorized Canon dealer or service representative to have the unit serviced.
- Before moving the scanner, make sure to turn the power switch OFF, and disconnect the power plug from the power outlet.
- Do not block the ventilation openings. Doing so could cause the scanner to overheat, creating a risk of fire.
- Never place small metal objects such as staples, paper clips, or jewelry on the scanner. These items may fall into the scanner, and cause a fire or electric shock. Should such objects ever fall inside the scanner, immediately turn the power switch OFF, and disconnect the power plug from the power outlet. Then, contact your local authorized Canon dealer or service representative to have the unit serviced.
- Do not locate the scanner in a humid or dusty location. Doing so may cause a fire or electric shock.
- Do not place objects on top of the scanner. Such objects may tip or fall over, resulting in personal injury.
- When unplugging the power cord, grasp it firmly by its plug. Do not pull directly on the power cord, as this may damage or expose the cord's internal wiring, resulting in a fire or electric shock.
- Leave sufficient space around the power plug so that it can be unplugged easily. If objects are placed around the power plug, you will be unable to unplug it in an emergency.
- Do not allow water or flammable substances (alcohol, paint thinner, benzene, etc.) to spill into the scanner, as this may result in a fire or electric shock.
- Turn OFF the power switch for safety when not using the scanner for a long period of time, such as overnight. Also, turn OFF the power switch, and disconnect the power cord from the power outlet for safety when the machine will not be used for an extended period of time, such as during consecutive holidays.

**CAUTION**

- Do not install the scanner on a surface that is unstable or tilted, or in an area subject to excessive vibrations, as this may cause the scanner to fall, resulting in personal injury or damage to the scanner.

- Do not wear loose clothing or jewelry that may get caught in the scanner while you are using it. This may result in personal injury. Be extra careful of neckties and long hair. If anything becomes caught in the scanner, immediately disconnect the power cord to stop the scanner.
- Be careful when placing paper in the scanner and when removing jammed paper. It is possible to cut your hand on the edge of a sheet of paper.

Disposal

- When disposing of this scanner, make sure to follow all local ordinances and laws or consult with the retailer who sold you the scanner.

2. Features

The main features of the DR-6050C/7550C/9050C are described below.

Scanner Features

- **Variety of Scanning Modes**

The scanner is equipped with six scanning modes: Black and White, Error Diffusion, Advanced Text Enhancement, Advanced Text Enhancement II, 256-Color Grayscale, and 24-Bit Color.

* Advanced Text Enhancement can clarify scanned text by processing background or foreground colors.

- **Fast Document Feeding**

The scanner can scan up to 90 document sheets per minute of LTR/A4-size paper in black and white, grayscale, and color scanning modes. (For the DR-9050C)

* Scanning conditions: LTR/A4 portrait, duplex, 200 dpi

- **Large Capacity Feeder**

Up to 500 plain paper document sheets can be loaded in the document feed tray. (Maximum of 300 sheets for the DR-6050C)

- **Count-Only Mode**

When operating the scanner as a stand-alone device, this mode counts the number of loaded document sheets. (See “Count-Only Mode” on p. 4-4.)

- **Adjustable Document Feed Tray**

The position of the document feed tray can be adjusted up or down according to the number of document sheets to be loaded. (See “Preparing the Document Feed Tray” on p. 3-6.)

- **Long Document Mode**

Document sheets up to three meters (118.1 inches) long can be scanned. (See “Long Document Mode Setting” on p. 3-4.)

- **Job Function**

Scanning conditions and the saving destination for image files are registered with the job, so you can scan using only control panel key operations. (See “About the Job Function” on p. 3-14.)

- **Freely Adjustable Document Guides**

The left and right document guides can be adjusted so that documents can be positioned to scan either the left or right side. (See “Adjusting the Document Guides” on p. 3-8.)

- **User Mode**

The User Mode functions can be employed to set the scanner for practically any condition. (See “User Mode Functions” on p. 4-10.)

Detection Functions

- **Auto Image Type Detection**
The scanner automatically detects whether documents are in black and white or color.
- **Auto Paper Size Detection**
The document page size is detected before scanning.

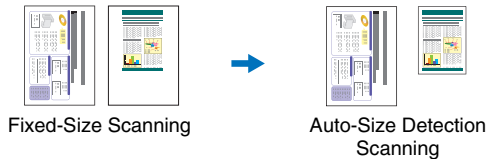

- **Skew Detection**
The scanner stops feeding when a skewed document is detected as it touches the edge of the feeder inlet. (See “Skew Detection” on p. 4-6.)
- **Staple Detection**
The scanner stops feeding when it detects the presence of stapled documents. (See “Staple Detection” on p. 4-6.)
- **Ultrasonic Double-Feed Detection**
The scanner stops feeding when the ultrasonic sensor detects that two or more document pages are feeding at the same time. (See “Double-Feed Detection” on p. 4-5.)
* A non-detection zone can be specified to avoid double-feed detection in areas such as those containing adhesive labels.
- **Double-Feed Detection by Document Length**
The scanner stops feeding when a double feed is detected by comparing document lengths. (See “Double-Feed Detection” on p. 4-5.)
* Using the length of the first document page as a reference, the scanner detects a double feed when a page of a different length is fed.

- **Prescan**
At the start of scanning, this function prescans the first page of a document and pauses so that you can use the first image to adjust the brightness and contrast before resuming scanning.
- **Verify Scan**
While scanning, the count of document pages scanned is verified against a pre-specified count or the count obtained from Count-Only Mode. (See “Verify Scan” on p. 4-4.)
- **Text Orientation Detection**
The text orientation on each page is detected, and the scanned image is rotated in 90-degree increments as necessary for normalization.

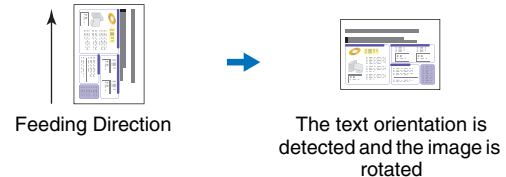
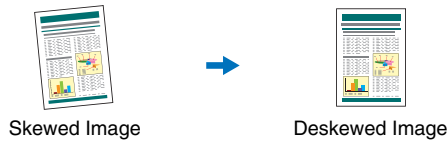

Image Processing

- **Prevent Bleed Through/Remove Background**
Prevents the background or original image on the reverse side of thin originals from appearing in scanned images.
- **Image Rotation**
The scanner can rotate scanned images in 90° increments, or detect the text orientation and rotate the image in 90° increments to correct its orientation.

● **Deskew**

The scanner straightens an image when it recognizes from the image that the document page was fed askew.



● **Dropout and Color Enhancement**

The scanner is equipped with drop-out and enhancement functions that enable you to specify one color (red, blue, or green) to be omitted (dropped out) or enhanced when scanning, respectively.



● **Remove Binder Holes**

Erases the shadows that appear on scanned images from binding holes on the original document.



● **Skip Blank Page**

The scanner scans both sides of a document and skips saving the image of any side it determines to be a blank page.



● **Folio Scan**

Documents that are too large to fit in the feeder inlet can be folded and scanned on both sides, and the images combined into a single image.

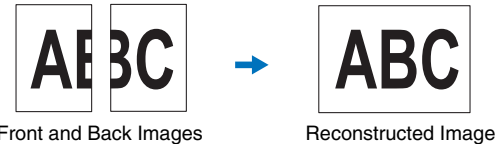

* Folio Scan supports up to A1-size (23.4" x 33.1" (594 x 841 mm)) documents when used together with the Long Document Mode.

● **MultiStream**

The scanner supports MultiStream, which, depending on the software application, can create two images with different scanning conditions from a single scan pass. However, this function is only available when using CapturePerfect 3.0 (supplied with the scanner) or another application program that supports the Multi-Stream function.

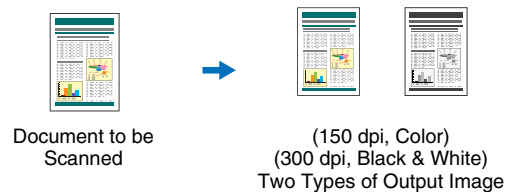

Other Functions

● Rapid Recovery System

When this function is activated and a sensor detects a misfeed due to a paper jam or double feed, which causes feeding to stop, scanning pauses to allow you to correct the cause of the misfeed, after which scanning continues from the document page on which the abnormality was detected. (See “Clearing a Paper Jam or Double Feed Error” on p. 3-23.)

* The Rapid Recovery System is effective when feeding stops as a result of detection of a Paper Jam, Double Feed, Skew, or Staple.

Options

● Imprinter (Option)

As an option, printing can be made on scanned documents.

● Barcode Detection (Option)

Barcodes on documents can be detected by installing the optional barcode module.

● Patchcode Support (Option)

By installing the optional patchcode decoder, patch code sheets inserted between document pages can be detected for batch separation. (See “Using Patchcode Sheets (Option)” on p. 3-20.)

3. Names and Functions of Parts

The names and functions of the DR-6050C/7550C/9050C parts are shown below.

Front View, Feeder Inlet, and Eject Outlet

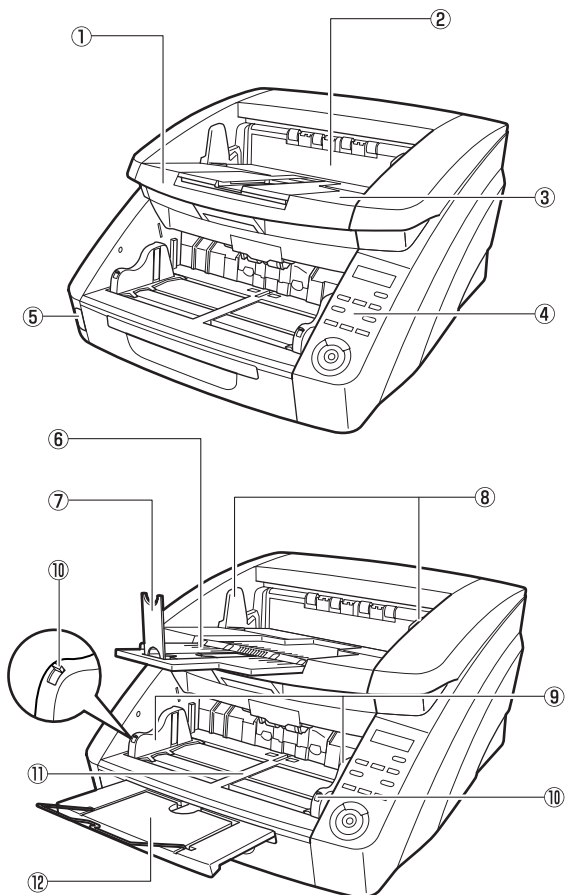

- ① Upper Unit
Open when cleaning the rollers or paper jams. (See p. 3-23.)
- ② Imprinter Cover
Open when replacing the ink cartridge in the optional imprinter or when cleaning the imprinter. (See p. 5-13.)
- ③ Document Eject Tray
Scanned documents are output here. (See p. 3-10.)
- ④ Control Panel (See p. 1-12.)
- ⑤ Power Switch
Turns the scanner ON and OFF. (See p. 3-2.)
- ⑥ Document Eject Tray Extension
Open the Document Eject Tray Extension when documents look like they are going to fall off of the eject tray. (See p. 3-10.)
- ⑦ Eject Paper Stoppers
Adjust to fit the length of documents, to avoid document spillage. (See p. 3-10.)
- ⑧ Document Guides
Adjust to fit the width of documents, so that ejected documents stack neatly. (See p. 3-10.)
- ⑨ Document Guides
Adjust to fit the width of documents. (See p. 3-8 and p. 3-9.)
- ⑩ Document Guide Lock Lever
Locks the Document Guides. (See p. 3-9.)
- ⑪ Document Feed Tray
Load documents to be scanned here. (See p. 3-6.)
- ⑫ Document Feeder Tray Extension / Extension Wire
Extend as needed to fit the length of the documents. (See p. 3-7.)

CAUTION

Do not open the imprinter cover if the optional imprinter is not installed.

Rear View

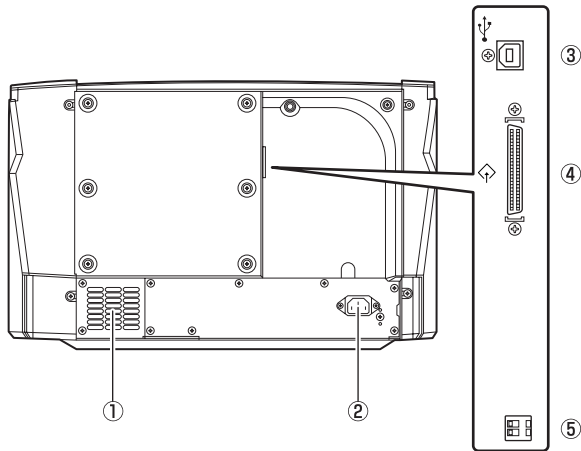

- ① **Ventilation Holes (Exhaust Fan)**
Exhausts heat from inside the scanner.
- ② **Power Connector**
Connect the supplied power cord here. (See p. 2-7.)
- ③ **USB Connector (Type B)**
Connect the supplied USB cable here. (See p. 2-6.)
- ④ **SCSI Connector (50-pin half-pitch D-sub receptacle)**
Connect the SCSI cable here. (See p. 2-7.)
- ⑤ **DIP Switches (SCSI ID)**
Selects the scanner's SCSI ID. (See p. 2-8.)

CAUTION

Do not block the ventilation holes. Doing so could cause the scanner to overheat, creating a fire hazard.

Control Panel

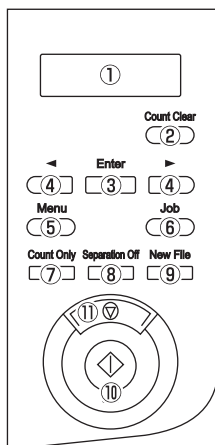

- ① **Display Panel**
Displays the user mode, job info, messages, and counter.
- ② **Count Clear Key**
Clears the counter on the display panel.
- ③ **Enter Key**
Selects the user mode, and accepts settings.
- ④ **◀▶ Keys**
Selects the user mode and job.
- ⑤ **Menu Key**
Displays the user mode. (See p. 4-8.)
- ⑥ **Job Key**
Selects jobs. (See p. 3-14.)
- ⑦ **Count Only Key**
Feeds and counts the number of document pages. (See p. 4-4.)
- ⑧ **Separation Off Key**
Raises the Document Feed Tray for the non-separating (manual) mode. (See p. 3-11.)
- ⑨ **New File Key**
When File Separation by Key is enabled, separates files.
- ⑩ **Start Key**
Starts scanning.
- ⑪ **Stop Key**
Stops the scanning process.

Chapter 2 Setup

1. Setup Procedures	2-2
2. Installation Requirements	2-3
3. Software Installation	2-4
About the Setup Menu	2-4
4. Connecting the Scanner to the Computer	2-6
Interface Connector Locations	2-6
Connecting the Scanner to the Computer	2-6
5. Turning the Power ON	
(Scanner Recognition)	2-9
About the Power Switch	2-9
Scanner Recognition	2-9

1. Setup Procedures

Perform the following setup procedures to prepare the scanner for use.

Step 1: Confirm the installation requirements. (See p. 2-3)

Step 2: Install the Software. (See p. 2-4)

Step 3: Connect the scanner to the computer. (See p. 2-6)

Step 4: Turn the power ON (Scanner recognition). (See p. 2-9)

! IMPORTANT

- Make sure that you install the software before connecting the scanner to the computer.
- If you connect the scanner to the computer before installing the software, a wizard screen such as the one shown below will appear when you turn the scanner ON. In this case, click [Cancel] to close the wizard screen, and then turn the scanner OFF.
- Windows 2000

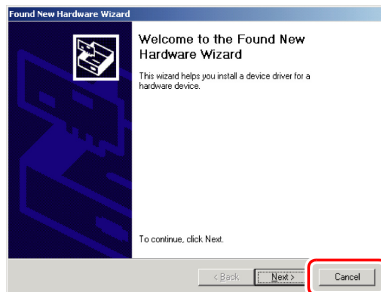

- Windows XP

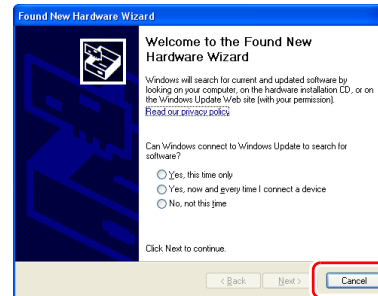

- Windows Vista

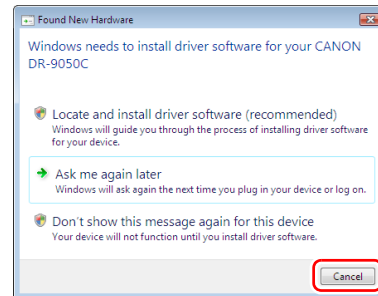

2. Installation Requirements

To use the scanner, your computer must satisfy the following system requirements.

■ Operating System:

- Microsoft Windows 2000 Professional SP4 or later
- Microsoft Windows XP Professional SP3 or later
- Microsoft Windows XP Home Edition SP3 or later
- Microsoft Windows XP Professional x64 Edition SP2 or later
- Microsoft Windows Vista Home Basic, Home Premium, Business, Ultimate or Enterprise SP1 or later



Hint

Microsoft Windows Vista has 32- and 64-bit versions.

■ Computer Specifications:

- CPU: Celeron, 1.6GHz or faster
- Memory: 512MB or more
- Hard disk: 1 GB or more available space
- CD-ROM drive
- Interface: One standard Hi-Speed USB 2.0 port on the PC, or a SCSI expansion card
- Monitor: Resolution of 1024 × 768 (XGA) or better recommended

■ Recommended SCSI Cards:

SCSI cards made by Adaptec (for PCI bus)

- AVA-2915LP
- AVA-2930LP

SCSI card made by RATO Systems (for Card bus)

- REX-CB31

■ An ISIS-compatible application or a TWAIN-compatible application that is compatible with the above operating systems.

! IMPORTANT

- If you do not know the requirements for your computer system, contact the store where you purchased the computer or the manufacturer of the computer for more information.
- Do not connect both a USB interface and a SCSI card at the same time.
- Note the following points when using the USB interface that was provided with your computer.
 - The USB connection should be a Hi-Speed USB 2.0 interface.
 - Scanning speeds are lower if your computer's standard USB interface is USB Full-Speed (equal to USB 1.1).
 - Use the most recently available USB 2.0 driver provided by Microsoft. Contact your local authorized Canon dealer for more detailed information.
 - Not all USB interfaces provided as standard with personal computers are guaranteed. Contact your local authorized Canon dealer for more detailed information.
 - Use the USB cable that was originally bundled with the scanner or a Hi-Speed USB 2.0 compatible cable.
- Note the following when using a SCSI card.
 - Make sure to follow the procedure in the manual for the SCSI card and the computer that you are using when installing a SCSI card in your computer.
 - The overall length of the SCSI cable you can use is determined by the SCSI standards. Refer to the manual for the SCSI card you are using for more information.
- If the CPU, memory, interface card, and other specifications do not satisfy the installation requirements, the scanning speed may be greatly reduced and transmission may take a longer time.
- Even if the computer satisfies the recommended specifications, the scanning speed may vary, depending on the scan settings.
- The ISIS/TWAIN Drivers provided with the scanner do not necessarily operate on all ISIS- or TWAIN-compatible applications. For details, contact your application software retailer.

3. Software Installation

This section describes how to install the software.

About the Setup Menu

When you insert the included Setup disc into the computer's CD drive, the menu shown below should appear. If the menu does not appear, use Explorer to access the CD drive and execute the file "SETUP.EXE".

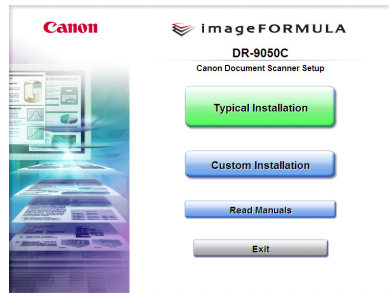

! IMPORTANT

- As always when installing software, log in using an account with Administrator privileges.
- When using Windows Vista, the "User Account Control" dialog box may appear. In this case, enter your login user password for Administrator privileges, and click [OK].

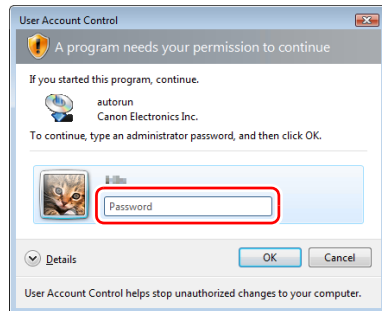

■ The Typical Installation Screen

This screen appears when you click "Typical Installation" on the Menu screen. Click [Install] to install all of the listed software.

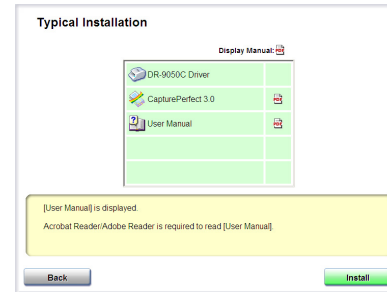

💡 Hint

See the *Easy Start Guide* for instructions on using the typical installation procedure.

■ The Custom Installation Screen

This screen appears when you click "Custom Installation" on the Menu screen. Select the check boxes next to the software that you want to install.

Click [Install] to install the selected software.

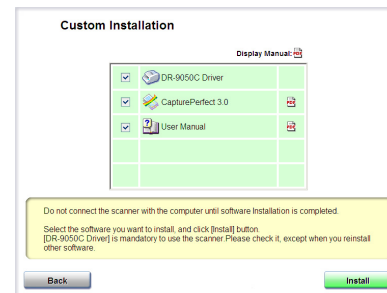

■ The Read Manual Screen

From this screen you can select one of the supplied electronic manuals to read: the *Easy Start Guide* (a printed copy is also supplied), the *Reference Guide*, the *User Manual* (this manual), or the *CapturePerfect 3.0 Operation Guide*.

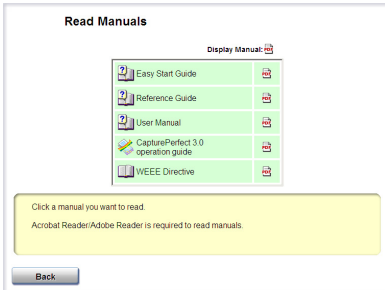

4. Connecting the Scanner to the Computer

There are two methods for connecting the scanner to a computer: a USB connection to a standard USB port built in to the computer, or SCSI connection to a SCSI card installed in an expansion slot of the computer. Select the method that is best suited to your computer environment.

Interface Connector Locations

The USB port and SCSI connector are located on the scanner as shown below.

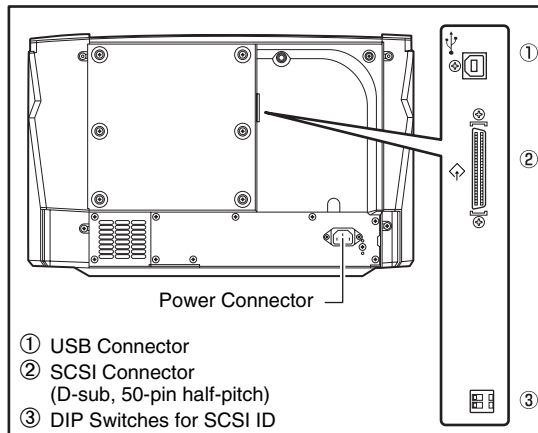

! IMPORTANT

- Do not connect a USB and SCSI cable to the scanner at the same time.
- Use only the supplied power cord.
- The scanner and computer should both be turned OFF when making connections.
- Make sure that the computer is turned OFF before connecting the SCSI cable. The scanner may not be properly recognized by the computer if it is connected while the computer is turned ON.
- A SCSI cable is not supplied with the scanner. Obtain a cable with connectors that match the SCSI connectors on both the scanner and the computer.

Connecting the Scanner to the Computer

To connect to the computer, follow the procedure for the intended connection method.

■ Using a USB Connection

1. Connect the supplied power cord into the power connector on the back of the scanner. ①
2. Connect the power cord into an AC outlet. ②

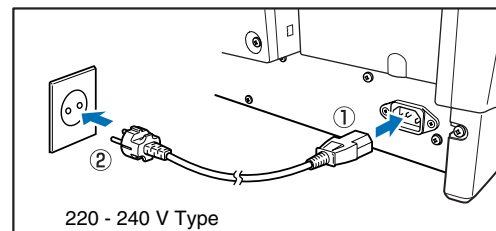
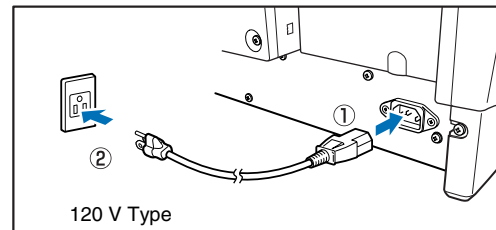

- 3.** Use the supplied USB cable to connect the scanner to the computer.
Connect the square plug (Type B) of the USB cable to the scanner.

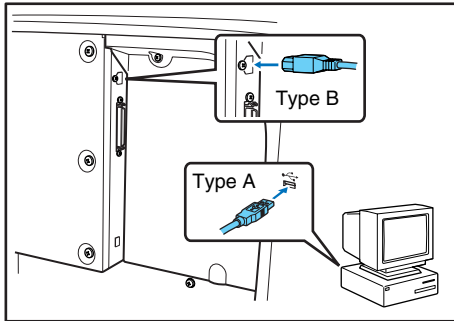

■ Using a SCSI Connection

! IMPORTANT

Make sure that the computer is turned OFF before connecting the SCSI cable. If the cable is connected while the computer is on, the scanner may not be properly recognized by the computer.

- 1.** Shut down Windows and turn the computer's power OFF.
- 2.** Connect the supplied power cord into the power connector on the back of the scanner. ①

- 3.** Connect the power cord into an AC outlet. ②

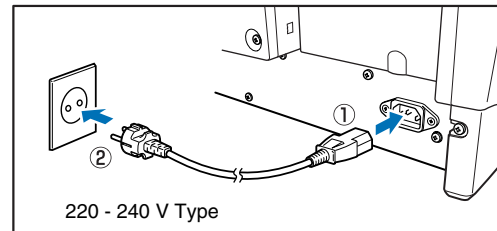
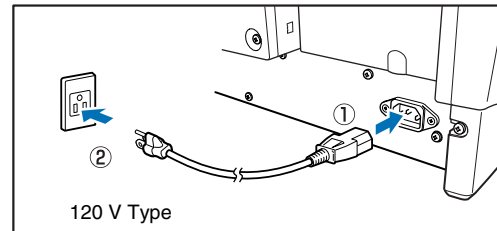

- 4.** Use the SCSI cable to connect the scanner to the computer.

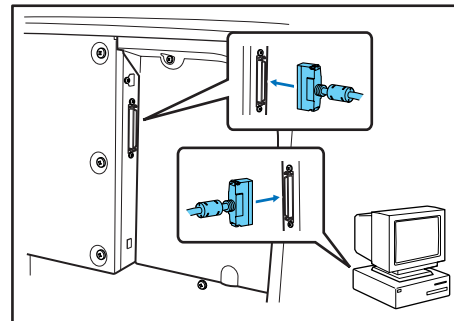

! IMPORTANT

Observe the following when connecting the scanner with other devices in a “daisy chain”.

- The SCSI ID of the scanner is set to “SCSI ID = 2” by default. When using a daisy-chain configuration with other SCSI devices, set the DIP switches so that SCSI ID numbers are not duplicated in the system.

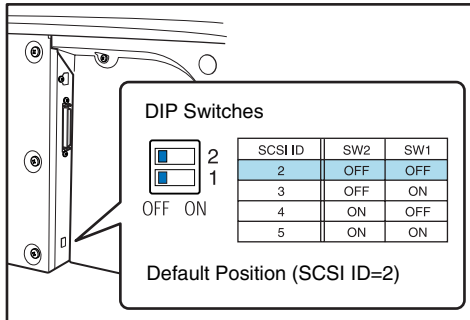

- The scanner incorporates a SCSI terminator which is permanently set to ON. When using a daisy-chain configuration with other SCSI devices, make sure that the scanner is connected as the last device in the chain. Set the terminators of all other devices to OFF.

5. Turning the Power ON (Scanner Recognition)

When you turn ON the computer and the scanner, the Windows Plug and Play function recognizes the scanner and automatically installs the required device driver.

About the Power Switch

The power switch is located at the lower left side of the front of the scanner. Press the power switch to turn the scanner ON.

(See p. 3-6.)

Press the power switch again to turn the scanner OFF.

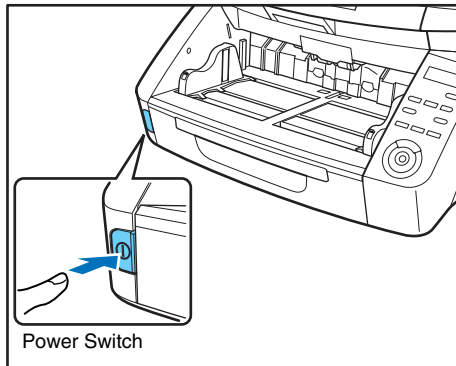

! IMPORTANT

- When connecting the scanner to the computer using a SCSI cable, be sure to turn ON the scanner first, and then turn ON the computer. If you turn ON the computer first, the scanner may not be properly recognized by the computer.
- After turning the scanner OFF, wait at least 10 seconds before turning it ON again.
- If you will not be using the scanner for an extended period, disconnect the power cord from the AC outlet for safety.

Scanner Recognition

The scanner will be recognized the first time it is connected to the computer.

1. Make sure that the scanner and computer are connected properly.
2. Turn ON the scanner.
3. Turn ON the computer.
4. Log onto Windows as an Administrator.
5. Windows automatically recognizes the scanner and performs the device driver installation.

- Windows 2000



- Windows XP



- Windows Vista

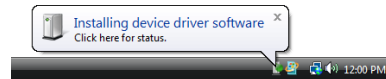

 **Hint**

- With Windows Vista, installation proceeds automatically regardless of the displayed “Click here for status” balloon help. You can click “Click here for status” to display the installation progress.

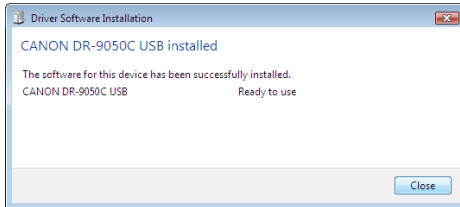

- With Windows XP and Vista, a message appears when installation is finished.

- Windows XP



- Windows Vista

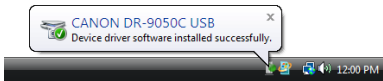

- The scanner is installed in Device Manager under [Imaging devices] as [CANON DR-XXXX USB] or [CANON DR-XXXX SCSI]. (XXXX varies depending on the model you are using)

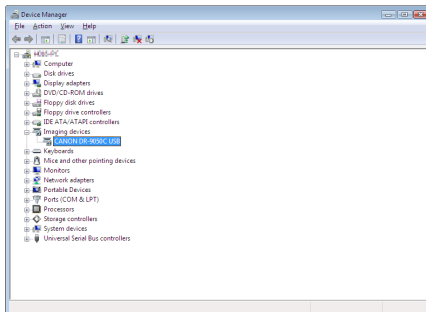

- From the Control Panel, you can display the Device Manager using the following procedure:
 - With Windows 2000, open [System] and click [Device Manager] on the Hardware tab sheet.
 - With Windows XP, first switch the Control Panel to the Classic View to display [System]. Then open [System] and click [Device Manager] on the Hardware tab sheet.
 - With Windows Vista, open [System and Maintenance] and click [Device Manager]. Or, switch the Control Panel to the Classic View and click the [Device Manager] icon.

Chapter 3 Basic Operation

1. Turning the Power ON and OFF.....	3-2
About the Power Switch.....	3-2
2. Documents.....	3-3
Acceptable Documents.....	3-3
3. Document Feed and Eject Trays.....	3-6
Preparing the Document Feed Tray.....	3-6
Adjusting the Document Guides.....	3-8
Preparing the Document Eject Tray.....	3-10
4. Document Feeding Methods.....	3-11
Selecting the Document Feeding Method.....	3-11
5. Scanning.....	3-14
About the Job Function.....	3-14
CapturePerfect 3.0.....	3-15
6. Using Patchcode Sheets (Option).....	3-20
About Patchcode Sheets.....	3-20
How to Use Patchcode Sheets.....	3-21
7. Clearing a Paper Jam or Double Feed	
Error.....	3-23
Paper Jam Handling.....	3-23
Handling a Double Feed.....	3-24

1. Turning the Power ON and OFF

Use the power switch to turn the scanner ON and OFF, or if you are using a USB connection, you can set the USB-linked power switch.

CAUTION

- After turning the scanner OFF, wait at least ten seconds before turning it back ON.
- If the scanner is connected via SCSI cable, always turn the scanner ON before turning the computer ON. If you turn the computer ON before the scanner, it may not recognize the scanner properly.

About the Power Switch

The power switch is located at the lower left side of the front of the scanner. Press the power switch to turn the scanner ON.

(See p. 3-6.)

Press the power switch again to turn the scanner OFF.

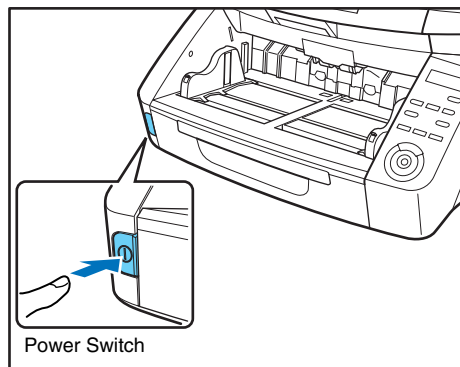

Hint

In the User Mode, if the tray position is set to a height other than the lowest position, then the Document Feed Tray moves up and down when the power is turned on. In this case, the Document Feed Tray is lowered once to the lowest position and then moves to the configured height. When the power is turned off, the Document Feed Tray does not move and stays at the configured height. (See p. 3-6.)

IMPORTANT

- When connecting the scanner to the computer using a SCSI cable, be sure to turn ON the scanner first, and then turn ON the computer. If you turn ON the computer first, the scanner may not be properly recognized by the computer.
- After turning the scanner OFF, wait at least 10 seconds before turning it ON again.
- If you will not be using the scanner for an extended period, disconnect the power cord from the AC outlet for safety.

2. Documents

The scanner can scan documents ranging in size from business cards and checks to 11" × 17"/A3 size. The size and type of paper that can be fed depends on the feeding method.

Acceptable Documents

The scanner can feed the following document sizes.

Size

Width: 2" to 12.01" (50.8 mm to 305 mm)

Length: 2.76" to 17.01" (70 mm to 432 mm) (without using the Long Document Mode)

2.76" to 39.37" (70 mm to 1m) (using [ON1] in the Long Document Mode)

2.76" to 118.11" (70 mm to 3m) (using [ON2] in the Long Document Mode)

Hint

When the Long Document Mode is selected, Paper Size Detection can be used for scanning documents up to 118.11" (3 m) long. (See "Long Document Mode Setting" on p. 3-4.)

Paper Thickness

Continuous Feeding: 14 to 56 lb bond (52 g/m² to 209 g/m²) (0.06 mm to 0.25 mm)

Manual Feeding: 11 lb to 64 lb bond (42 g/m² to 255 g/m²) (0.05 mm to 0.30 mm)

Hint

- Continuous feeding feeds document pages one after another by the feed and retard rollers after placing a batch of documents in the Document Feed Tray.

- Manual feeding requires feeding one document at a time while the [Separation Off] key on the control panel is lit and the Document Feed Tray is raised.

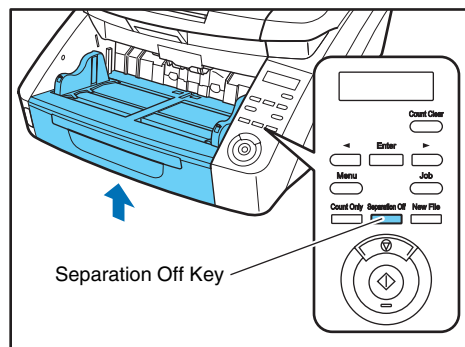

IMPORTANT

A document must meet the following criteria to be scannable:

- When scanning a multipage document, pages must be grouped together so that they have the same size, thickness, and weight. Scanning different types of paper at one time can cause the scanner to jam.
- Always make sure that the ink on a document is dry before scanning it. Scanning documents with the ink still wet may soil the rollers or scanning glass, cause lines or smudges to appear on images, or dirty other documents.
- Always clean the rollers or scanning glass after scanning a document written in pencil. Scanning documents with pencil written on them may soil the rollers or scanning glass, cause stripes to appear in images, or dirty other documents.
- When scanning a two-sided document that is printed on thin paper, the image on the opposite side of each page may show through. Adjust the scanning brightness from the application program, or enable the [Prevent Bleed Through/Remove Background] setting before scanning.

- Note that scanning the following types of documents can cause a paper jam or malfunction. To scan such a document, make a photocopy of the document and then scan the photocopy.



Wrinkled or creased documents



Carbon paper



Curled documents



Coated paper



Torn documents



Extremely thin, translucent paper



Documents with paper clips or staples

- To scan bound multi-page documents such as invoice booklets, place the bound edge against the feeder inlet and scan by manual feeding.
- To use the Long Document Mode, feed document pages manually, one after another.

Document Feeder Capacity

DR-6050C:

Up to 300 sheets of good quality paper or up to 1.10" (28 mm) high (maximum)

DR-7550C/9050C:

Up to 500 sheets of good quality paper or up to 1.89" (48 mm) high (maximum)

! IMPORTANT

Do not exceed the load limitation mark when placing documents in the Document Feed Tray. It may cause paper jams.

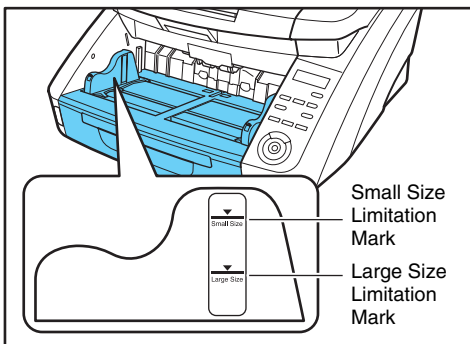

Small Size Limitation Mark:

When placing documents that are smaller than LTR/A4 size.

Large Size Limitation Mark:

When placing documents that are larger than LTR/A4 size.

■ Long Document Mode Setting

Using the Long Document mode, pages up to 118.11" (3 m) long can be scanned. You can set the Long Document Mode setting from the User Mode.

- Press the Menu key on the control panel.

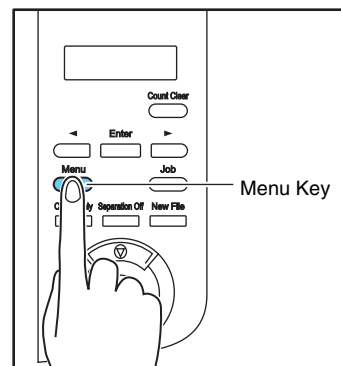

The User Mode is activated.

```
B u z z e r   C o n t r o l
[ O N 2 ]   O N 1   O F F
```

- Press the [▶] key four times to display Long Document Mode. (See p. 4-8.)

```
L o n g   D o c u m e n t
O N 2   O N 1   [ O F F ]
```

3. Confirm your settings.

[ON2]: When the [Auto Detection] or [Scanner's Maximum] page size setting is selected, document page lengths up to 118.11" (3 m) can be detected.

[ON1]: When the [Auto Detection] or [Scanner's Maximum] page size setting is selected, document page lengths up to 39.37" (1 m) can be detected.

[OFF]: When the [Auto Detection] page size setting is selected, document page lengths up to 17.01" (432 mm) can be detected.

4. Press [Enter].

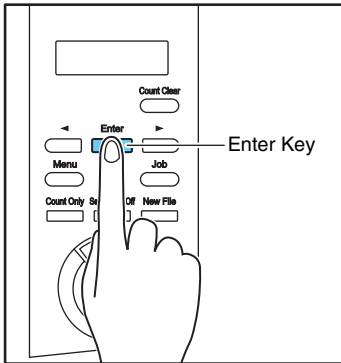

The current setting is indicated by blinking square brackets [].

5. Press the [◀] or [▶] key to select [ON] or [OFF], and press [Enter] to accept the selection.

6. Press the Stop key to exit the User Mode.

! IMPORTANT

- Processing may be slowed when scanning in the Long Document Mode.
- When scanning with the Long Document Mode set to [ON1], if the scan is performed with the scanning mode set to color and the image quality set to [Image quality priority], the image may be lost. If this occurs, scan by using black and white or reducing the image quality.

- When scanning with the Long Document Mode set to [ON2], if the scan is performed at 400/600 dpi or the scan is performed with the scanning mode set to color and the scanning side set to [Duplex], the image may be lost. If this occurs, scan by reducing the resolution, using black and white, or setting the scanning side to [Simplex].
- When scanning using Long Document Mode, [High-Quality Moire Reduction], [Deskew], or document orientation of [90 degrees] or [270 degrees] cannot be used.
- If a sheet is loaded at a skewed angle when scanning long documents, it may be damaged by contacting both sides of the transport path. So be careful to avoid loading documents at skewed angles.
- Paper jam detection may react slowly when scanning long documents, which could result in jammed documents being damaged. Be especially careful to avoid paper jams.
- To feed each document page manually when scanning long documents, press the [Separation Off] key on the control panel.

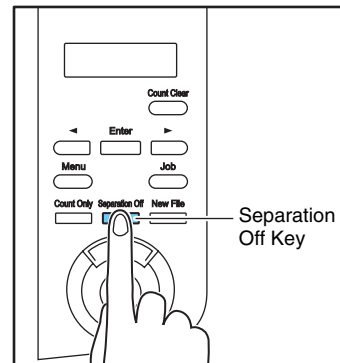

3. Document Feed and Eject Trays

Before scanning, prepare the Document Feed and Eject Trays for the desired paper size.

Preparing the Document Feed Tray

■ Document Feed Tray

The height of the Document Feed Tray can be adjusted according to the number of document pages to be loaded (the default setting is the lowest position).

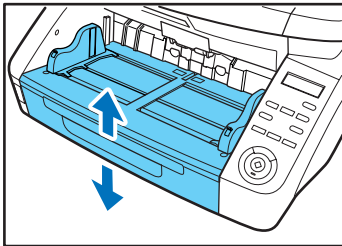

Tray Position Setting

The height of the Document Feed Tray is set by the Tray Position in the User Mode setting, which minimizes the time required to start feeding by specifying in advance the proper position for the documents to be loaded.

1. Press the Menu key on the control panel.

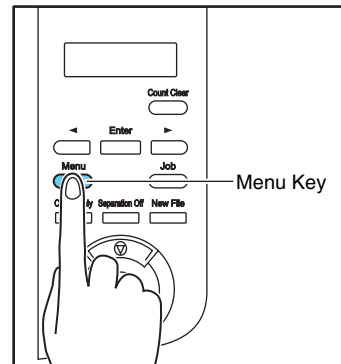

The User Mode is activated.

```
Buzzer Control
[ ON 2 ] ON 1 OFF
```

2. Press the [◀] key five times to display Tray Position. (See p. 4-8.)

```
Tray Position
      2      1      [ 0 ]
```

3. Confirm your settings.

For the DR-6050C

[0]: To load up to 300 sheets

[1]: To load up to 100 sheets

For the DR-7550C/9050C

[0]: To load up to 500 sheets

[1]: To load up to 300 sheets

[2]: To load up to 100 sheets

4. Press [Enter].

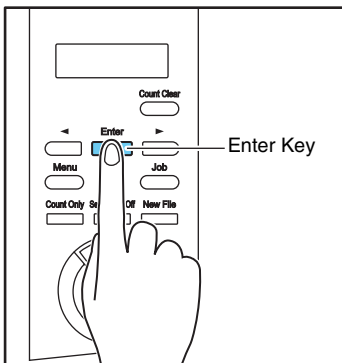

The current setting is indicated by blinking square brackets [].

5. Press the [◀] or [▶] key to select [0], [1] or [2].

6. Press [Enter] to accept the selection.

The Document Feed Tray moves to the selected height.

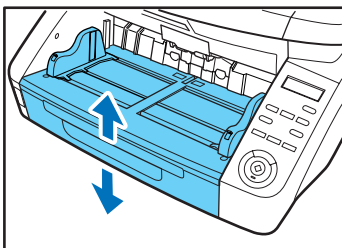

7. Press the Stop key to exit the User Mode.

■ Document Guides

Slide the document guides to fit the width of your document.

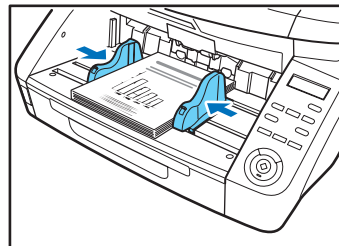

Hint

The positions of the left and right document guides can also be locked independently for off-center loading. For details, see [“Adjusting the Document Guides” \(p. 3-8\)](#).

■ Document Feeder Tray Extension / Extension Wire

Pull out the tray extension as needed for the length of your document.

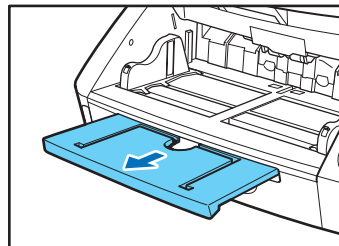

Gently open the extension wire.

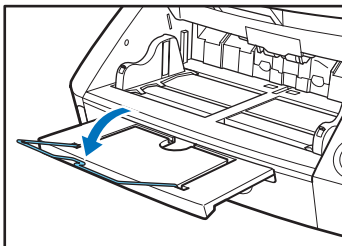

 **Hint**

Use the extension wire if the document extends beyond the edge of the document tray.

Adjusting the Document Guides

The document guides normally extend at equal distances from the left and right of the center of feeding so that your documents are centered in the feed inlet.

However, each document guide has its own lock lever, so you can load documents to the left or right of center by locking the document guides at the appropriate positions.

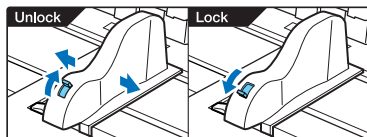

■ Loading Documents at the Left Side

This example shows the procedure for loading documents at the left side of the feeder.

1. Spread the document guides all the way to the left and right.

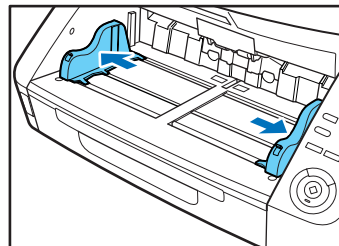

2. Load your documents against the left feed guide.

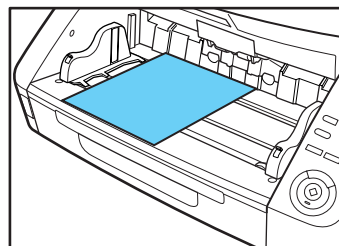

3. Lock the left document guide (①) by pulling out the lock lever, then slide the right document guide to the right edge of your documents (②).

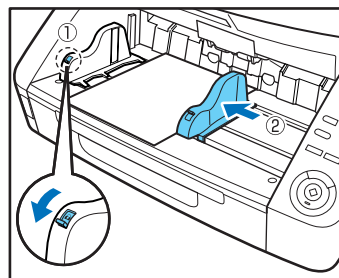

4. Lock the right document guide (①), and unlock the left document guide (②).

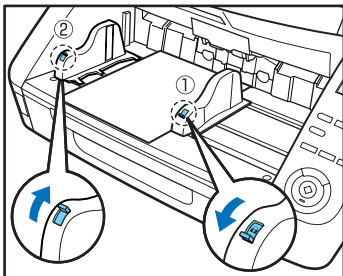

5. Slide the left document guide to the left edge of your documents.

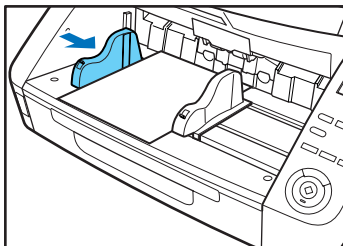

■ Resetting the Document Guides

To reset the guides so that they are equidistant from the center, perform the following procedure to spread the guides to the left and right as far as they will go.

1. Confirm that the right document guide is locked (①), and slide the left guide all the way to the left (②).

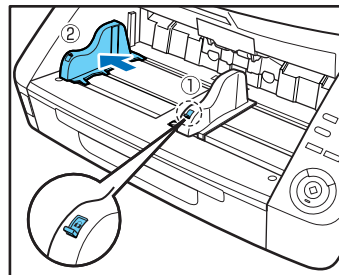

2. Lock the left document guide (①), and unlock the right document guide (②).

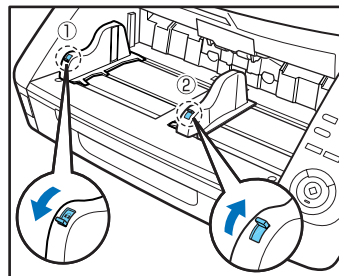

3. Slide the right document guide all the way to the right.

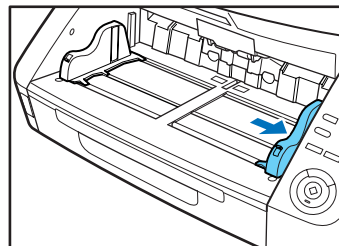

4. Unlock the left document guide.

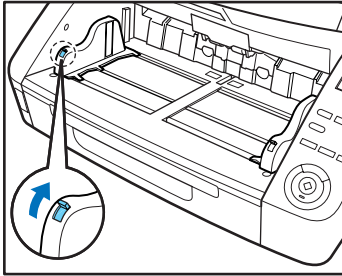

Preparing the Document Eject Tray

The Eject Tray includes two Document Eject Guides, the Eject Tray Extension and Eject Paper Stopper, to be adjusted to fit the width and length of your documents.

■ Document Guides

Slide the document eject guides to fit the width of your documents.

The eject position of the document can be checked by feeding a single sheet of the document in Count-Only Mode. (See “Count-Only Mode” on p. 4-4.)

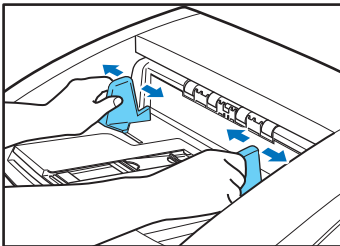

■ Document Eject Tray Extension

Open the Document Eject Tray Extension when documents look like they are going to fall off of the eject tray.

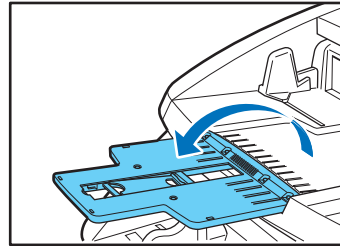

■ Eject Paper Stoppers

Raise the appropriate Eject Paper Stoppers to stop ejected documents from spilling out of the eject tray.

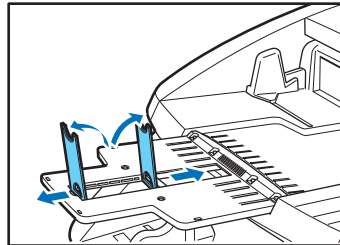

Hint

The eject paper stoppers are attached to the document eject tray extension, so you can adjust their positions to suit your document length.

When an LTR/A4-size paper is loaded, close the document eject tray extension and stand up the upper eject paper stoppers. When an A3-size paper is loaded, open the document eject tray extension and stand up the upper eject paper stoppers.

4. Document Feeding Methods

Two document feeding methods are available: Continuous Feeding, which feeds documents automatically from the document tray by the pickup roller; and Manual Feeding, which requires one document at a time to be positioned manually for transport by the feed roller, while the pickup roller is disabled.

Selecting the Document Feeding Method

Continuous Feeding is the default feeding method, but Manual Feeding can be enabled by selecting Manual Feeding as the Feeding Option for the ISIS/TWAIN driver, or by pressing the Separation Off key on the control panel. A Continuous Manual Feeding Mode is also provided as a way to scan a batch of document pages that cannot be automatically transported.

Continuous Feeding

With Continuous Feeding, documents loaded in the Document Feed Tray are picked up automatically by the pickup roller and transported by the feed roller, while the retard roller separates each page to avoid double feeding.

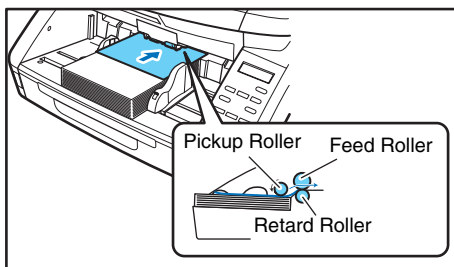

Manual Feeding

The Separation Off key lights and the Document Feed Tray rises so that documents can be fed manually one at a time.

When manual feeding, you must insert each document page far enough to be pulled in by the feed roller (because the pickup roller is disabled).

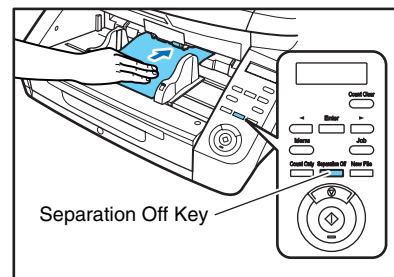

! IMPORTANT

- Because pages are not separated by the retard roller during manual feeding, a paper jam will occur if multiple pages are loaded together.
- To scan bound multi-page documents such as invoice booklets, place the bound edge against the feed inlet and scan using manual feeding.

💡 Hint

- The [Separation Off] key is linked to the [Manual Feeding] Feed Option setting (p. 8-20) of the ISIS/TWAIN driver.
- When the [Separation Off] key on the control panel is pressed or the [Manual Feeding] Feed Option is selected, the [Separation Off] key lights and the Document Feed Tray rises.

Continuous Manual Feeding Mode

Enable the Continuous Manual Feeding Mode from the User Mode when document pages do not separate well using Continuous Feeding.

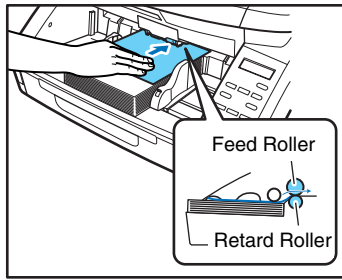

! IMPORTANT

When the Continuous Manual Feeding Mode is set to ON from the User Mode, make sure to disable it (set to OFF) when finished scanning. Otherwise, normal continuous feeding will be disabled the next time someone uses the scanner.

💡 Hint

For Manual Feeding, you must feed document one page at a time. For Continuous Manual Feeding, you must place the documents on the Document Feed Tray and insert them into the Document Feed Tray opening one page at a time, making operation easier.

■ Continuous Manual Feeding Mode Setting

Select Manual Feed Mode in the User Mode settings to enable continuous manual feeding.

1. Press the Menu key on the control panel.

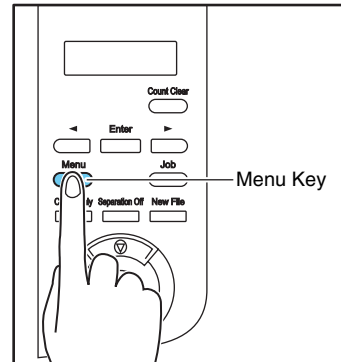

The User Mode is activated.

```
Buzzer Control
[ ON 2 ] ON 1 OFF
```

2. Press the [▶] key five times to display "Manual Feed Mode". (See p. 4-8.)

```
Manual Feed Mode
ON [ OFF ]
```

3. Confirm your settings.

[ON]: Disables the pickup roller so that loaded documents have to be hand fed to the feed roller one page at a time.

[OFF]: Documents are fed continuously by the pickup roller, except when the Separation Off key is lit.

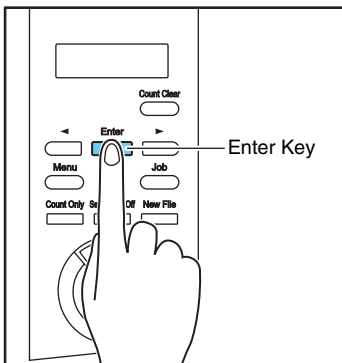
4. Press [Enter].

The current setting is indicated by blinking square brackets [].

- 5.** Press the [◀] or [▶] key to select [ON] or [OFF], and press [Enter] to accept the selection.
- 6.** Press the Stop key to exit the User Mode.

5. Scanning

Scanning operations can be controlled by a scanning application program such as the CapturePerfect 3.0 software included with the scanner, or directly from the control panel of the DR-6050C/7550C/9050C, using the Job Function. This section describes the Job Function and provides an overview of CapturePerfect 3.0.

About the Job Function

The Job Function enables you to use the Job Registration Tool to register different jobs which can then be selected for scanning by pressing the [Job] key on the control panel. Job registration stores scanning condition settings, image file format selection, save destination, and image data processing settings for each job to be used with the Job Function.

Hint

The Job Registration Tool is a TWAIN-compliant application that is installed along with the ISIS/TWAIN driver. See [Chapter 9 “Job Registration Tool Settings”](#) for details.

■ Executing Jobs

Use the following procedure to execute jobs that have been registered by the Job Registration Tool.

1. Press the Job key on the control panel.

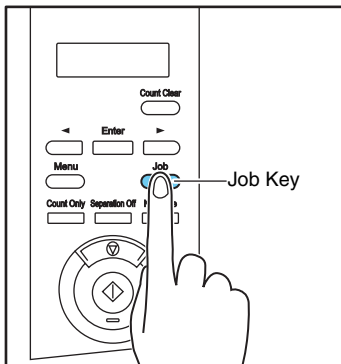

Registered jobs are displayed.

```
0 1 : A 4   B / W   2 0 0
D o c u m e n t s
```

Hint

If no job is displayed, you must register a job using the Job Registration Tool.

2. Press the [◀] or [▶] key to select a job.
3. Execute the displayed job by pressing the Start key.

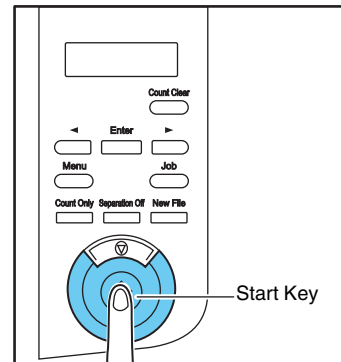

4. Open the folder specified during job registration to confirm that the image files have been created.

CapturePerfect 3.0

CapturePerfect 3.0 is an ISIS-compatible application developed for Canon document scanners.

CapturePerfect 3.0 includes the following modes. Select the desired scan mode from the Scan menu to perform scanning.

For more information on CapturePerfect 3.0, refer to the *CapturePerfect 3.0 Operation Guide*.

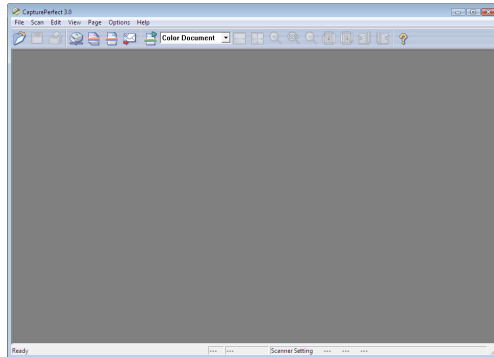

■ Scanning with CapturePerfect

The following three scanning methods are available from the CapturePerfect Scan menu.

Scan Batch to Printer

Prints scanned images on a specified printer



Scan Batch to File

Saves scanned images as files in a specified folder



(Network)

Scan Batch to Mail

Starts your e-mail program and attaches the scanned image to a new e-mail message

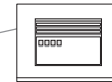

Scan Batch to File

Documents are scanned with the preset scanning conditions, and the scanned image data is saved to a specified folder.

Scan Batch to Printer

Documents are scanned with the preset scanning conditions, and the scanned image data is printed on a specified printer.

Scan Batch to Mail

Scanning is performed with the specified scanning conditions, and a MAPI-compliant e-mail client is started to generate a new e-mail message with the scanned images as attachments.

Scan Page

Only one page of the document is scanned.

Scan Job

The scanning conditions and scan mode (Scan Batch to File, Scan Batch to Printer, or Scan Batch to Mail) are registered in advance as a job. The scan job can then be performed by selecting the registered job from the drop-down list (①) or by clicking (Scan Job) on the toolbar (②).

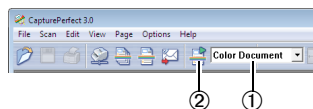

Hint

The following two scan jobs are already registered and up to 99 additional jobs can be registered.

- Color Document
Scan the document using 24-bit color, simplex, at 300 dpi resolution, and save the file in the folder [Pictures].
- Binary Document
Scan the document in black-and-white, simplex, at 200 dpi resolution, and save the file in the folder [Pictures].

Scan To Presentation

This mode is convenient when a compact scanner is used in an environment such as a conference hall, where it is connected to a large display or projector. By setting CapturePerfect for full-screen display before scanning, scanned images are displayed at full size on the screen.

Hint

This function is not usually practical for large scanners.

■ Using CapturePerfect 3.0

This section describes how to start CapturePerfect 3.0 and scan documents. The procedure for using the Scan Batch to File function is described here as an example. For details, refer to the *CapturePerfect 3.0 Operation Guide*.

1. From the Windows task bar, click [Start] → click [All Programs] → [CapturePerfect 3.0] → [CapturePerfect 3.0].

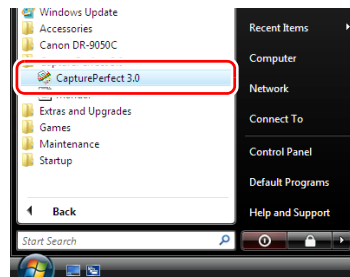

CapturePerfect 3.0 starts.

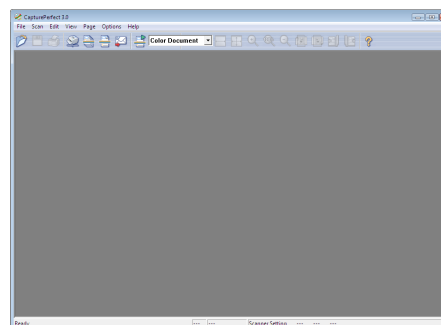

2. From the [Scan] menu, select [Select Scanner].

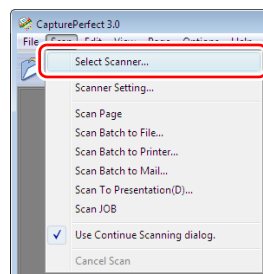

The [Select Scanner] dialog box opens.

3. Select [CANON DR-XXXX] and click [Settings].
(XXXX varies depending on the model you are using)

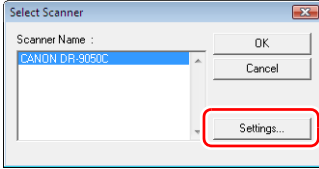

! IMPORTANT

If [CANON DR-XXXX] is not displayed in the list of scanners, you must re-install the ISIS/TWAIN driver.

4. Select the default page size and click [OK].

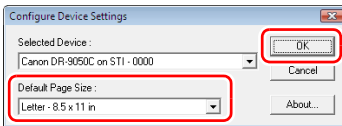

! IMPORTANT

If you select [Default] in the ISIS driver properties dialog box, that setting is applied here.

5. Click [OK] to finish scanner selection.
6. From the [Scan] menu, select [Scan Batch to File].

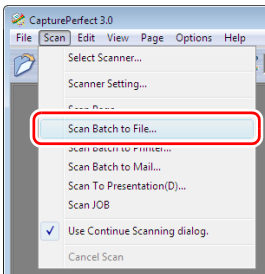

The [Scan Batch to File Setting] dialog box opens.

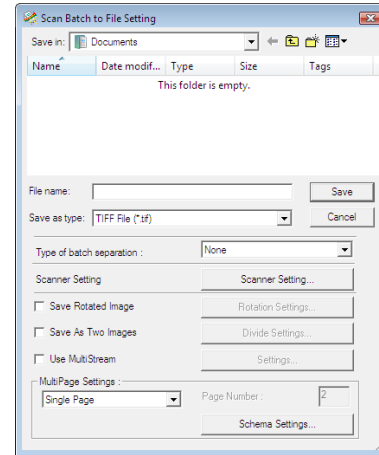

7. Click the [Scanner Setting] button.

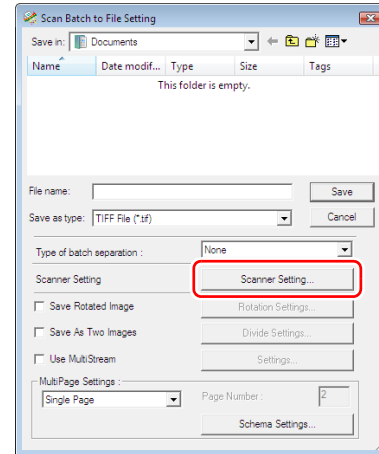

The Properties dialog box for the ISIS driver opens.

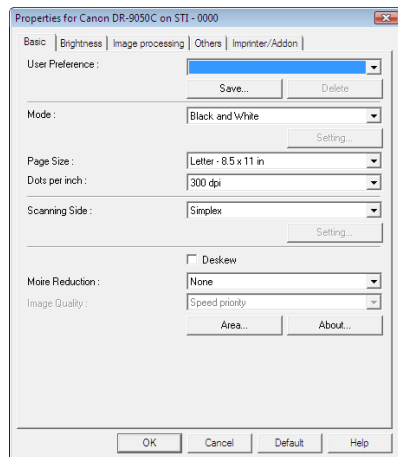

8. Set the scan settings.



Hint

For more information on specifying the scan settings, see “ISIS/TWAIN Driver Settings Dialog Box” on p. 8-4.

9. Click the [OK] button to exit the scanner settings.

10. Specify the file name and the file type for saving the image data.

For details on the available settings in the [Scan Batch to File Setting] dialog box, refer to the *CapturePerfect 3.0 Operation Guide*.

11. Place your document and click [Save] to start scanning.

! IMPORTANT

You must load your documents as described below, depending on the specified Feed Option setting.

- If the [Standard Feeding] Feed Option is enabled, load your documents before scanning. When all of the documents have been scanned, the Continue Scanning dialog box appears.

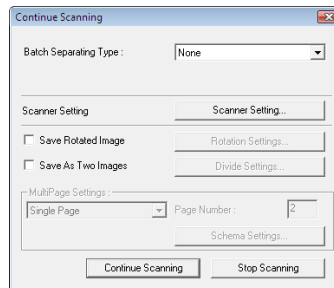

- If the [Manual Feeding] Feed Option is enabled, the Separation Off key is lit and the Document Feed Tray is raised. You must insert one page at a time to be scanned, and press the Stop key to display the Continue Scanning dialog box.

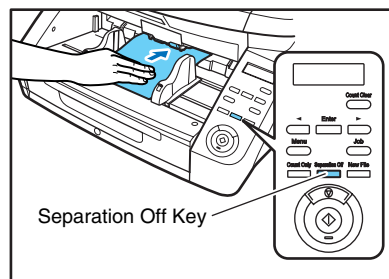

- If a Feed Option other than [Standard Feeding] or [Manual Feeding] is selected, once you have started scanning, each document placed in the Document Feed Tray is scanned, and when no document is loaded, the scanner enters the standby state.

- If the [Automatic Feeding] Feed Option is enabled, scanning is performed automatically whenever a sensor in the Document Feed Tray detects a loaded document, and pressing the Stop key causes the Continue Scanning dialog box to appear.
- If the [Panel-Feeding] Feed Option is enabled, the Start key lamp is lit. You must load a document and press the Start key to scan. Pressing the Stop key causes the Continue Scanning dialog box to appear.

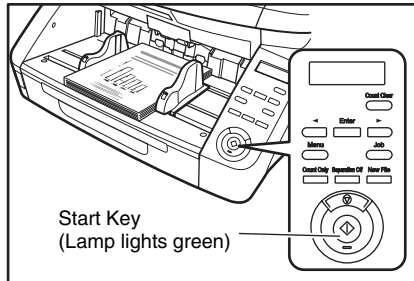

12. When the [Continue Scanning] dialog box appears, verify that a document is loaded, and click either [Continue Scanning] or [Stop Scanning].

! IMPORTANT

If Use Continue Scanning dialog in the [Scan] menu is not checked, scanning finishes without displaying the Continue Scanning dialog box.

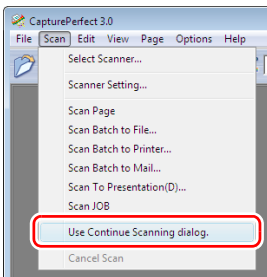

13. When scanning is complete, select [Exit] from the [File] menu to quit CapturePerfect 3.0.

6. Using Patchcode Sheets (Option)

When the optional patchcode decoder is installed, the DR-6050C/7550C/9050C supports Automatic File Separation by detecting patchcode sheets inserted within a document, and performs batch separation.

About Patchcode Sheets

Patchcode patterns are printed on the patchcode sheets used to automatically separate files. Patchcode pattern icons are registered in the following location when the ISIS/TWAIN driver is installed.

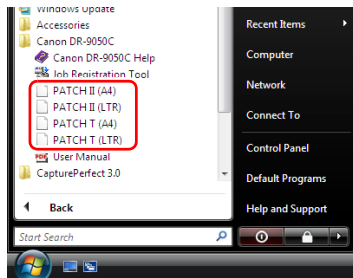

! IMPORTANT

- Patchcode sheets can be used only when the application you are using supports separating files by patchcode patterns.
- Patchcode sheets are data in PDF format. There are four types; [PATCH II (A4)], [PATCH II (LTR)], [PATCH T (A4)], [PATCH T (LTR)], organized according to the paper size and pattern.
- Patchcode sheets cannot be used when the MultiStream function (See "MultiStream" on p. 1-8.) is being used by CapturePerfect 3.0.

■ Printing Patchcode Sheets

Open the desired patchcode sheet file with an application that supports CapturePerfect 3.0 or the PDF file format, and print the page image only at its original size.

! IMPORTANT

- Print (at original size) PATCH T (A4) and PATCH II (A4) sheets on A4-size paper, or PATCH T (LTR) and PATCH II (LTR) on LTR paper.

- Patchcode sheets must be printed in their original size. The scanner may not recognize them as patchcode sheets if they are enlarged or reduced.

■ Patchcode Pattern Function

There are two types of patchcodes, and their function changes according to their pattern.

PATCH T



When the scanner recognizes this patchcode printed on a patchcode sheet, it creates a separate file for the document that comes after the patchcode sheet. The image of this sheet can be saved or not, depending on the application's settings.

PATCH II



When the scanner recognizes this patchcode printed on a patchcode sheet, it creates a separate file starting from the patchcode sheet. The image of this sheet is saved, regardless of the application's settings.

How to Use Patchcode Sheets

This section describes how to use patchcode sheets with CapturePerfect 3.0.

1. Print the patchcode sheets on a printer.

! IMPORTANT

- Print (at original size) PATCH T (A4) and PATCH II (A4) sheets on A4 paper, or PATCH T (LTR) and PATCH II (LTR) on LTR paper.
- The scanner may not recognize the patchcodes if they are enlarged or reduced.

2. Insert the patchcode sheet in front of the document that you want to save as a separate file before placing the documents on the scanner.

Insert patchcode sheets in front of the documents you want to save as separate files.

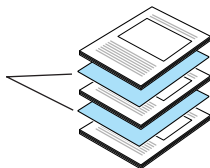

3. On the [Other] tab of the ISIS driver properties, select [Patchcode] from the Batch Separation drop-down list.

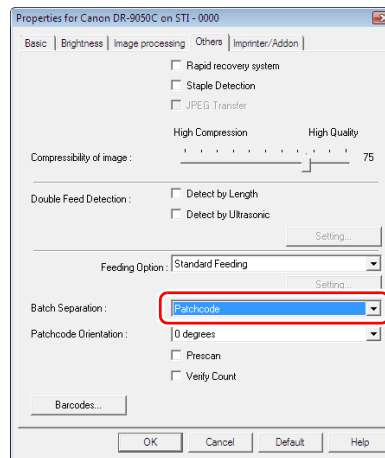

! IMPORTANT

If the patchcode decoder is not installed, the [Patchcode] batch separation setting is not displayed. (See "Batch Separation" on p. 8-20.)

4. Perform scanning with batch separation enabled.

5. Set the [Type of batch separation] setting to [Scan, Continue Scanning] or [Skip, Continue Scanning].

💡 Hint

- If [Scan, Continue Scanning] is selected or if the patchcode is PATCH II type, the patchcode sheet image is also saved and scanning continues.
- If [Skip, Continue Scanning] is selected and the PATCH T pattern is detected, the patchcode sheet image is not saved and scanning continues.

■ Creating a Patchcode Sheet

To copy a patchcode pattern to create a different size patchcode sheet, make sure to pay attention to the following precautions:

! IMPORTANT

- Adjust the patchcode so that it fits into the effective area for detecting patchcode patterns.

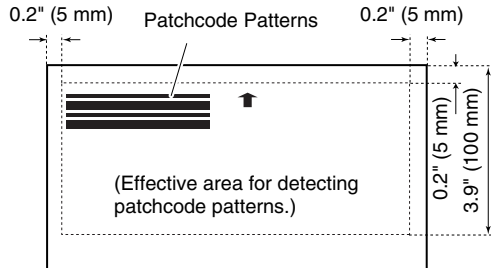

- When copying a patchcode pattern, the copy should be the same size as the pattern on the original.
- Be careful to keep patchcode sheets clean. If a patchcode sheet has been folded or becomes creased, reprint or replace the sheet.

7. Clearing a Paper Jam or Double Feed Error

If a paper jam or double feed occurs during scanning, a paper jam message appears on the PC and on the scanner's display panel. Use the following procedure to clear the paper jam.

⚠ CAUTION

- When removing jammed paper, take care not to cut your hands on the edges of the paper.
- Make sure to remove all of the jammed paper. Torn paper remaining in the scanner may cause future jams or damage to the scanner.
- When opening and closing the upper unit, be careful not to get your fingers caught, as this may result in personal injury.

Paper Jam Handling

When a paper jam occurs during scanning, the following message appears on the display panel, and transport stops.

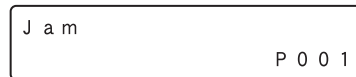

💡 Hint

The displayed error code indicates the location of the paper jam. For details, see "Error Messages" on p. 6-3.

1. Remove any documents that remain in the eject tray.
2. Press the Open/Close button and gently raise the upper unit.

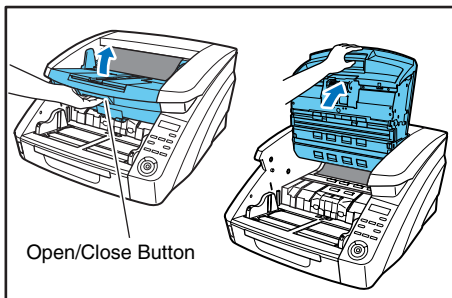

3. Remove the jammed paper.

⚠ IMPORTANT

- If paper has stopped in the midst of ejecting to the eject tray, raise the upper unit slightly to remove it.
 - To remove paper that has stopped inside the scanner, open the upper unit as far as it will go.
4. Close the upper unit slowly (①). Make sure that the upper unit is completely closed by pushing on both edges with both hands until you hear a click (②).

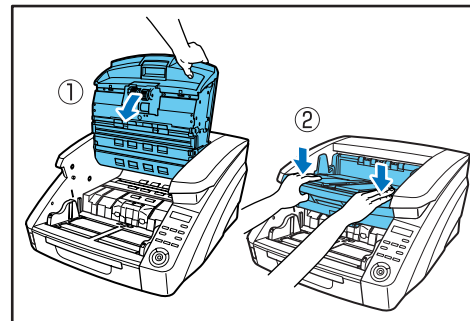

5. Check to verify the last saved image, and resume scanning.

■ When “Press Start Key” Appears

When the Rapid Recovery System is enabled in the ISIS/TWAIN driver settings, the following message appears on the display panel after you remove the jammed paper.

P r e s s S t a r t K e y

! IMPORTANT

The Rapid Recovery System setting in the ISIS/TWAIN driver causes the following process to occur after a paper jam. (See “[Rapid Recovery System] Check Box” on p. 8-18.)

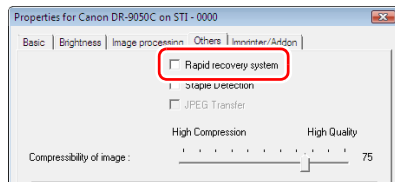

- When the Rapid Recovery System is disabled, images scanned before the paper jam occurs are saved as files, scanning finishes, finished and an error message is displayed. In this case, restart scanning from the document page where the paper jam occurred, or from the beginning.
- When the Rapid Recovery System is enabled, scanning pauses when a paper jam is detected, and an error message is displayed.

Return the jammed document page to the top of the document stack yet to be scanned, and press the Start key to resume scanning.

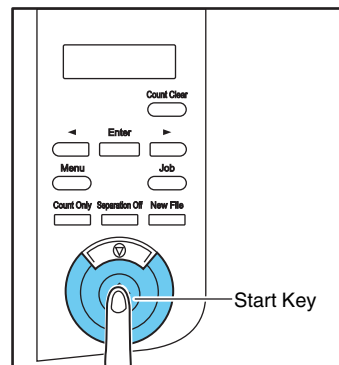

! IMPORTANT

- When you press the Start key, the image of the document page that caused the paper jam is deleted before scanning resumes.
- If you press the Stop key, the images of pages prior to the paper jam being detected are saved and the scan ends. In this case, restart scanning from the document page where the paper jam occurred, or from the beginning.

Handling a Double Feed

When a double feed is detected while scanning, an error message appears on the PC and on the display panel, and transport stops.

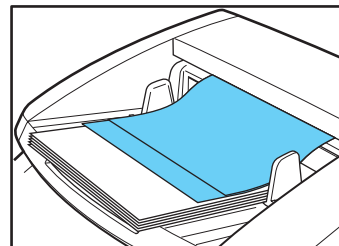

! IMPORTANT

When a double feed is detected, the following process occurs, and messages appear according to the Rapid Recovery System setting in the ISIS/TWAIN driver. (See “[Rapid Recovery System] Check Box” on p. 8-18.)

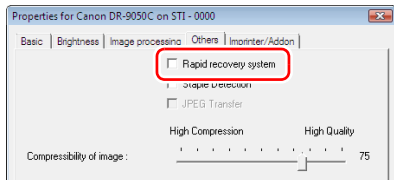

- When the Rapid Recovery System is disabled, images scanned before the double feed are saved as files, scanning finishes, and the following error message is displayed.

When detecting double feeds by document length

```

D B L   F e e d
                                D 0 0 2
  
```

When detecting double feeds ultrasonically

```

D B L   F e e d
                                D 0 0 4
  
```

- When the Rapid Recovery System is enabled, scanning pauses when a double feed is detected, and the following error message is displayed.

```

D B L   F e e d
  [ I G N O R E ]   R E T R Y
  
```

■ When the Rapid Recovery System is Disabled

Return the double-fed document pages to the top of the document stack yet to be scanned, and resume scanning.

■ When the Rapid Recovery System is Enabled

1. Check the double-fed document page(s).

💡 Hint

- If attached paper, such as a label on the document page, appears to be the cause of the double-feed detection, ignore the detection.
- If two document pages were fed together, rescan the double-fed pages.

2. Press [◀] or [▶] to select [IGNORE] or [RETRY] and press the [Enter] key.

```

D B L   F e e d
  [ I G N O R E ]   R E T R Y
  
```

[IGNORE]:

Saves the image of the page that was detected as a double feed, and resumes scanning.

[RETRY]:

The display panel appears as below. Return the double-fed document pages to the tray and press the Start key.

```

P r e s s   S t a r t   K e y
  
```

! IMPORTANT

- Press the Start key to erase the image that was being scanned when double feeding was detected, and resume scanning.
- If you press the Stop key, the images of pages prior to the double feed being detected are saved and the scan ends. In this case, restart scanning from the document page where the double feed is detected, or from the beginning.

Chapter 4 Other Functions

1. Other Functions and Settings	4-2
2. Function Description	4-4
3. User Mode	4-8
User Mode Operating Procedure	4-8
4. User Mode Functions.....	4-10

1. Other Functions and Settings

The following DR-6050C/7550C/9050C functions are grouped together as Other Functions. For details, refer to the indicated pages.

	Operation/Setting Method			Applicable Page
	Panel Operation (Not in User Mode)	Panel Operation (In User Mode)	ISIS/TWAIN	
SCSI Speed	–	✓	–	p. 4-11
USB Short Packet	–	✓	–	p. 4-11
Imprinter (Optional)	–	–	✓	p. 4-7, p. 8-25
Imprinter Test	–	✓	–	p. 4-12, p. 5-17
Counter (Total Counter)	–	✓	–	p. 4-12
Count (Roller Counter)	–	✓	–	p. 4-12
Count-Only Mode	✓	–	–	p. 4-4
Display Contrast	–	✓	–	p. 4-11
Key Repeat	–	✓	–	p. 4-12
Skew-Detection (Always On)	–	–	–	p. 4-6
Deskew	–	–	✓	p. 8-9
Double-Feed Detection	–	–	✓	p. 4-5, p. 8-19
Double-Feed Detection (Count-Only Mode)	–	✓	–	p. 4-10
Staple Detection	–	–	✓	p. 4-6, p. 8-19
Staple Detection (Count-Only Mode)	–	✓	–	p. 4-10
Staple Detection Level Setting	–	✓	–	p. 4-6, p. 4-10
Stand-by Mode	–	✓	–	p. 4-11
Long-Document Mode	–	✓	–	p. 3-4
Tray Position	–	✓	–	p. 3-6, p. 4-11
Folio Scan	–	–	✓	p. 4-6, p. 8-9
Buzzer (Beeper) Control	–	✓	–	p. 4-10
Verify Scan	✓	–	✓	p. 4-4
Manual Feed Mode	–	✓	–	p. 3-11, p. 4-11



- The Operation/Setting Methods are as follows:
 - Panel Operation: The operation or setting is performed using the control panel keys.
 - User Mode: The scanner function setting is made as a User Mode selection.
 - ISIS/TWAIN: The function is an ISIS/TWAIN driver scanning setting.
- The page count for the Verify Scan operation is entered using the control panel keys, and the operation is then executed by selecting Verify Count from the ISIS/TWAIN driver.

2. Function Description

The Other Functions are described below. See “User Mode” on p. 4-8, for descriptions of the functions set from the User Mode.

■ Count-Only Mode

Counts the number of loaded document sheets by simply feeding them through the scanner.

Hint

The Count-Only mode is executed by the Count Only key on the control panel, and can be used to count document sheets even when no computer is connected.

1. Place the documents into the tray.
2. Press the Count Only key on the control panel.

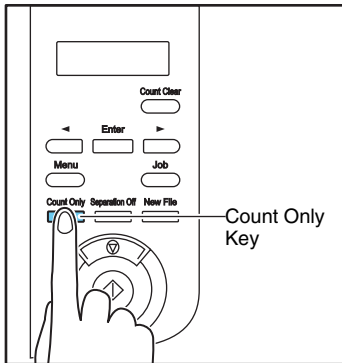

The Count Only key lights green when the Count-Only mode is enabled.

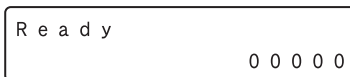

3. Press the Start key to start scanning and count the loaded document sheets.

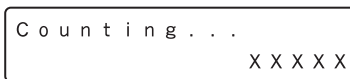

IMPORTANT

To reset the page counter, press the Count Clear key for approximately two seconds while the Count Only key is lit.

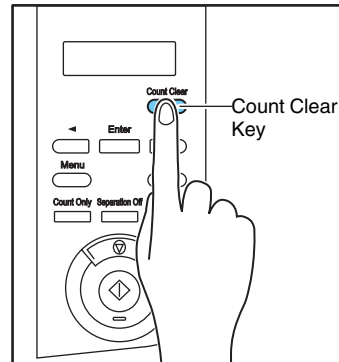

■ Verify Scan

The scanner compares the document page count obtained from the Count-Only mode (or entered manually) with the actual count of document pages scanned, and an error message is displayed if the counts do not match.

1. Setting the Count.

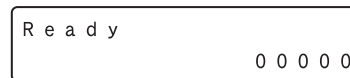

Hint

The document page count can be specified by using the count obtained from the Count-Only mode or by pressing the [◀] and [▶] keys to enter a number.

2. Select Verify Count in the ISIS/TWAIN driver settings. (See “[Verify Count] Check Box” on p. 8-22.)

3. Press the Start Key to start scanning.
“Verifying...” is displayed.

```

V e r i f y i n g . . .
                                X X X X X
  
```

 **Hint**

If the specified count is exceeded while scanning, or if the scanned count does not reach the specified count when scanning is finished, an error is displayed.

The specified count is exceeded while scanning

```

C o u n t   M i s m a t c h
                                U 0 0 1
  
```

Scanning finishes without reaching the specified count

```

C o u n t   M i s m a t c h
                                U 0 0 2
  
```

■ Double-Feed Detection

The scanner can detect double feeds. Two detection methods are used: comparison of document lengths, and ultrasonic detection of spacing between documents, which is set in the ISIS/TWAIN driver.

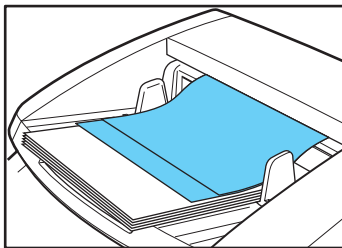

! IMPORTANT

- The message that appears when a double feed is detected depends on the Rapid Recovery System setting specified in the ISIS/TWAIN driver. See “When the Rapid Recovery System is Enabled” on p. 3-25 for details.

```

D B L   F e e d
                                D 0 0 4
  
```

- Double feed detection in the Count-Only mode is set in the User Mode, and double feeds are detected ultrasonically. (See “Double-Feed Control Setting” on p. 4-10.)

Detecting Double Feeds by Document Length

This detection method is effective when scanning documents with pages of the same size. The length of the first page scanned serves as a standard for comparing subsequent pages, and when a page is detected to be approximately 1.4 inches (35 mm) longer or shorter than the standard, a double feed is detected and document transport is stopped.

Ultrasonic Double-Feed Detection

This detection method is effective when scanning documents with pages of different sizes. The space between overlapping pages is detected ultrasonically, and document transport stops when a double feed is detected.

! IMPORTANT

- Ultrasonic double-feed detection works only when the document pages overlap by at least two inches (50 mm).
- If documents stick together due to static electricity, Ultrasonic Double-Feed Detection may not function correctly.
- If the presence of adhesive notes or labels on pages is detected as a double feed and you do not want to remove them for scanning, a non-detection zone can be specified in the ISIS/TWAIN driver settings. (See “Double Feed Detection” on p. 8-19.)

■ Skew Detection

If a long document page becomes skewed as it is fed, the page may press against the edge of the feed inlet or transport path and be damaged.

When the scanner detects that a skewed page is contacting the edge of the transport path, an error message is displayed and transport stops.

S k e w D e t e c t e d
J 0 1 8

! IMPORTANT

- A page that becomes skewed while it is fed is only detected by the sensors as skewed if it contacts the edge of the transport path during scanning.
- Note that the ISIS/TWAIN driver has a Deskew function that can detect a skewed document from the scanned image, and straighten it.

■ Staple Detection

When sensors at both sides of the feed inlet detect the bent corner of a stapled document, an error message appears and feeding stops.

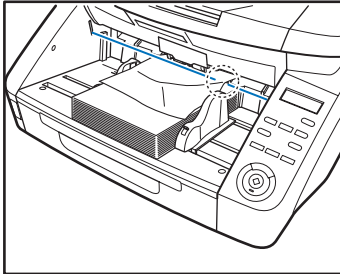

S t a p l e D e t e c t e d
J 0 0 1

! IMPORTANT

- Staple detection detects the bent corner that occurs when one of the four corners of a document has been stapled.

- Staple detection may not operate properly in the following cases where bending does not occur in documents.
 - The document is stapled at two or more corners.
 - The document is size smaller than STMT/A5.
 - The position of the left or right document guide has been changed, and the document has been shifted to the left or right side. (See “Adjusting the Document Guides” on p. 3-8.)

💡 Hint

- Staple detection is controlled in the ISIS/TWAIN driver, and the detection level can be set in the User Mode. (See “Staple Detection Level Setting” on p. 4-10.)
- Staple detection for the Count-Only mode can be set in the User Mode. (See “Staple Detection Setting” on p. 4-10.)

■ Folio Scan

Use Folio Scan to scan very large documents (up to 22" × 34"/A1 size) by folding each document sheet and scanning the front and back. The resulting images are then recombined to reconstruct an image of the entire page.

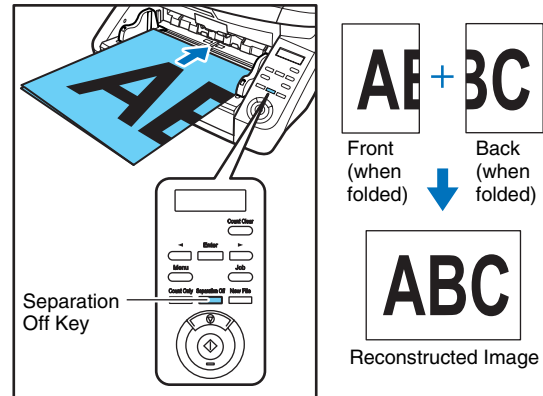

! IMPORTANT

- Folio scanning requires that you feed each page manually (The Separation Off key is lit).
- Fold each page with a sharp, straight crease. Otherwise, the paper may jam or the image may be misaligned.

- Seam artifacts may appear in the reconstructed image because of the crease line or differences in the loading position of each side.
- Load the document with the crease line on the right side.
- The scan image of the front side becomes the left half of the reconstructed image.
- The maximum document size for Folio Scan is 22" × 34"/A1.
- 22" × 34"/A1 document pages should be folded lengthwise and scanned with the following settings:
Scanner: Long Document Mode [ON1]
Page Size: Auto-Detection
- If scanning is performed when Long Document Mode is enabled, the image may be lost. Set Long Document Mode to [OFF] except when scanning 22" × 34"/A1 document pages.
- If scanning is performed with the scanning mode set to color, image quality set to [Image quality priority], and scanning side set to [Duplex], the image may be lost. If this occurs, scan by using black and white, reducing the image quality, or setting the scanning side to [Simplex].

**Hint**

Folio Scan is performed by setting the scanning side to [Folio] in the ISIS/TWAIN driver. (See p. 8-9.)

■ Imprinter (Optional)

An imprinter that prints on scanned documents is available as an option. For details, contact your dealer or service representative.

**Hint**

- The text to print and the printing position can be specified in the ISIS/TWAIN driver. (See p. 8-25.)
- Even if the imprinter is not installed, you can add a specified text string onto scanned images.

3. User Mode

The User Mode provides the user with the capability to change certain scanner functions.

User Mode Operating Procedure

User Mode operations are controlled by the following procedure.



Hint

Operating procedures differ according to User Mode function. For details, refer to the indicated pages.

1. Press the Menu key on the control panel.

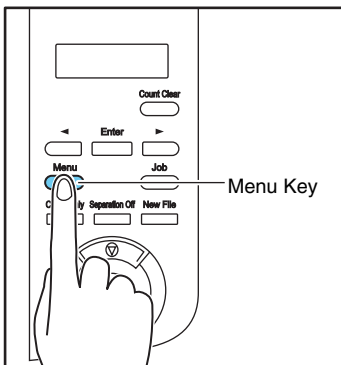

The User Mode is activated.

```
Buzzer Control
[ON2] ON1 OFF
```

2. Press the [◀] and [▶] keys to select the User Mode function.

```
Long Document
ON2 ON1 [OFF]
```

The User Mode functions are displayed in the following sequence.

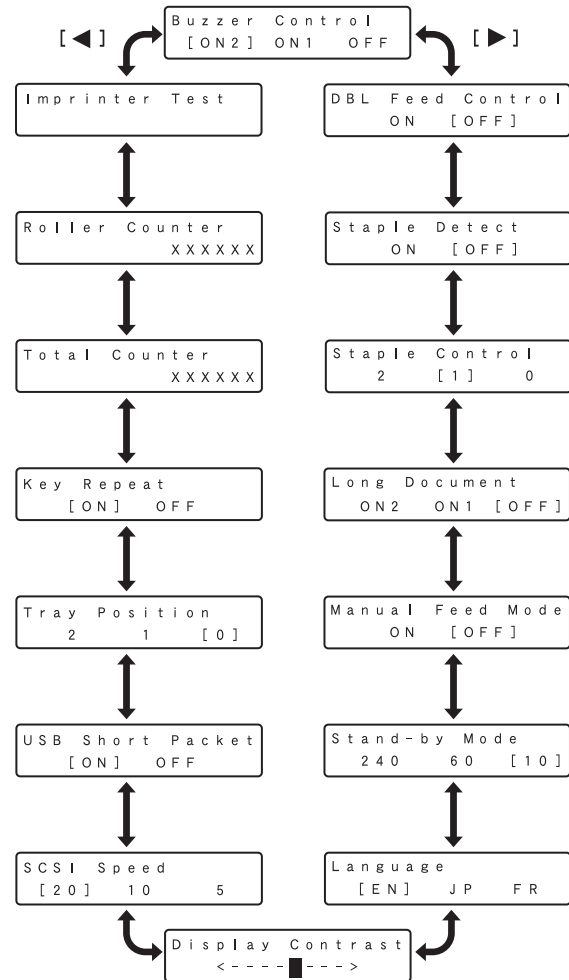

3. Press [Enter].

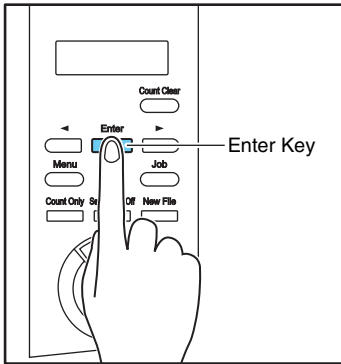

The current setting is indicated by blinking square brackets [].

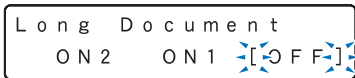

4. Press the [◀] or [▶] key to select [ON2], [ON1] or [OFF], and press [Enter] to accept the selection.



5. Press the [Stop] key to exit the User Mode.

4. User Mode Functions

The following functions are available in the User Mode.

■ Buzzer (Beeper) Control Setting

```
B u z z e r   C o n t r o l
[ O N 2 ]  O N 1   O F F
```

The beeper (“buzzer”) sounds when you press the control panel keys and when a scanning error occurs.

ON2: The beeper sounds when a scanner error occurs, and when a control panel key is pressed.

ON1: The beeper sounds when a scanner error occurs.

OFF: The beeper never sounds.

■ Double-Feed Control Setting

```
D B L   F e e d   C o n t r o l
O N   [ O F F ]
```

Select whether double-feed detection is enabled when the Count-Only mode is enabled. If you set DBL Feed Control to [ON], double feeds are detected during feeding in the Count-Only mode. (See “Double-Feed Detection” on p. 4-5.)

■ Staple Detection Setting

```
S t a p l e   D e t e c t
O N   [ O F F ]
```

Select whether staple detection is enabled when the Count-Only mode is enabled. (See “Staple Detection” on p. 4-6.)

ON: Detects staples in the Count-Only mode.

OFF: Does not detect staples in the Count-Only mode.

■ Staple Detection Level Setting

```
S t a p l e   C o n t r o l
2           [ 1 ]   0
```

Sets the staple detection sensitivity level.

[1] is the default setting, [2] provides higher sensitivity, and [0] provides lower sensitivity.

■ Long Document Mode Setting

```
L o n g   D o c u m e n t
O N 2   O N 1   [ O F F ]
```

You can enable this mode to detect and scan document pages up to 118.11" (3 m) long when the Auto Detection page size setting is selected. (See “Long Document Mode Setting” on p. 3-4.)

ON2: Automatically detects page sizes when scanning documents up to 118.11" (3 m) long.

ON1: Automatically detects page sizes when scanning documents up to 39.37" (1 m) long.

OFF: Automatically detects page sizes when scanning documents up to 17.01" (432 mm) long.



Hint

Feeding a document longer the maximum detectable page size for Auto Detection causes a paper jam indication, and transport stops.

■ Continuous Manual Feeding Mode Setting

```
Manual Feed Mode
  ON  [ OFF ]
```

This mode disables automatic feeding by the pickup roller, so that the loaded document stack must be fed by hand one sheet at a time by the operator. (See “Continuous Manual Feeding Mode” on p. 3-12.)

ON: The pickup roller is disabled.

OFF: Documents are fed by the pickup roller.

■ Stand-by Mode Setting

```
Stand-by Mode
 240   60  [ 10 ]
```

Selects the amount of time (240, 60 or 10 minutes) from when the scanner is last used to when the Stand-by mode is activated.

■ Display Language Setting

```
Language
  [ EN ]  JP  FR
```

Selects English, Japanese or French for the language to display on the control panel.

EN: English display panel

JP: Japanese display panel

FR: French display panel

■ Display Contrast Adjustment

```
Display Contrast
  < - - - - █ - - - - >
```

Use to adjust display panel contrast.

■ SCSI Speed Setting

```
SCSI Speed
 [ 20 ]  10   5
```

Selects the scanner’s SCSI transfer speed.

If the scanner does not operate normally with the default [20] (20 MBytes/s) speed, change this setting to reduce the speed to [10] (10 MBytes/s) or [5] (5 MBytes/s).

■ USB Short Packet Setting

```
USB Short Packet
  [ ON ]  OFF
```

If the scanner does not operate normally when using the USB interface, change this setting to [OFF].

■ Tray Position Setting

```
Tray Position
  2       1   [ 0 ]
```

The document feed tray should be set to fit the number of document sheets to be loaded. (See “Preparing the Document Feed Tray” on p. 3-6.)

For the DR-6050C

0: Up to 300 sheets

1: Up to 100 sheets

For the DR-7550C/9050C

0: Up to 500 sheets

1: Up to 300 sheets

2: Up to 100 sheets

■ Key Repeat Setting

```

Key Repeat
  [ ON ] OFF

```

Selects the panel display method.

ON: The panel display scrolls when a key is pressed continuously.

OFF: The panel display scrolls each time a key is pressed.



Hint

Key repeat is valid in the following situations.

- When using the Job Function
- When selecting each of the functions in the User Mode

■ Total Counter

```

Total Counter
          X X X X X X

```

Displays the lifetime total number of document pages fed by the scanner.

■ Roller Counter

```

Roller Counter
          X X X X X X

```

Displays the number of document pages fed since roller installation or replacement (pickup, feed, and retard rollers). Make sure to reset this counter when replacing the rollers. (See [“Checking and Resetting the Page Counter” on p. 5-5.](#))

■ Imprinter Test

```

Imprinter Test

```

When the optional imprinter is installed, this function executes a test printing of the imprinter. (See [“Performing an Imprinter Test” on p. 5-17.](#))

Chapter 5 Maintenance

1. Regular Maintenance.....	5-2
Cleaning the Scanner.....	5-2
Cleaning the Sensors.....	5-2
Cleaning the Scanning Glass and Rollers.....	5-3
Power Outlet	5-4
2. Replacing the Transport Rollers	5-5
Roller Replacement Cycle.....	5-5
Checking and Resetting the Page Counter.....	5-5
Removing and Reinstalling the Rollers	5-7
3. Imprinter Ink Cartridge Replacement and Cleaning.....	5-13
About the Imprinter.....	5-13
Replacing Ink Cartridges.....	5-13
Specifying the Printing Position.....	5-15
Cleaning the Imprinter.....	5-16
Imprinter Testing	5-17

1. Regular Maintenance

To maintain scanning quality, routinely clean the scanner as described below.

⚠ CAUTION

- Do not use spray cleaners to clean the scanner. Precision mechanisms may get wet and malfunction.
- Never use paint thinner, alcohol, or other organic solvents to clean the scanner. Such solvents may deform or discolor the exterior of the scanner, and cause other damage.
- When opening and closing the upper unit, be careful not to get you fingers caught, as this may result in personal injury.

Cleaning the Scanner

■ About the Cleaning Cloth

Use the cleaning cloth supplied with the scanner to clean its interior.

■ Cleaning the Scanner Exterior

To clean the outside of the scanner, use a cloth moistened with water or mild detergent solution. Wring out the cloth thoroughly, and use a clean dry cloth to wipe the scanner dry.

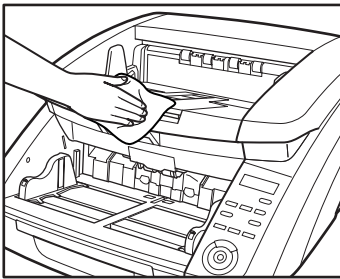

■ Cleaning the Document Feed Inlet and Transport Path

Dust or paper particles in the document feed inlet or inside the scanner can cause spots to appear in scanned images. Use compressed air to periodically clean dust and paper particles from the inlet and the inside of the scanner. After completing large scanning jobs, turn OFF the scanner and clean out any paper particles.

Cleaning the Sensors

Dust and debris that collects on the sensors may cause documents to be recognized incorrectly. Clean the sensors periodically using a blower, etc. so that dust and debris do not collect on them.

Main unit inner lower side

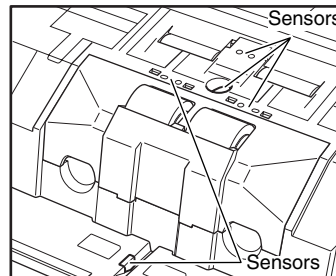

Main unit inner upper side (Upper Unit)

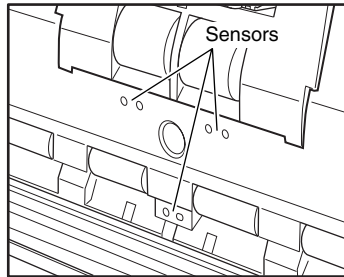

Cleaning the Scanning Glass and Rollers

If scanned images contain spots or documents become dirty after scanning, the scanning glass or transport rollers inside the scanner may be dirty. Please clean periodically.

! IMPORTANT

Scratches on the scanning glass may cause spots or streaks on scanned images, as well as feeding errors. If you find a scratch on the scanning glass, contact your local authorized Canon dealer or service representative to have the glass replaced.

1. Turn the power switch off, and disconnect the power plug from the power outlet.
2. Close the document eject tray extension if it is open.

3. Press the Open/Close button and carefully raise the upper unit until it stops.

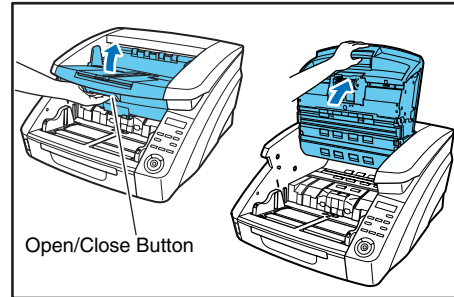

4. Wipe any dust off the scanning glass with a cleaning cloth or a clean, dry cloth.
Make sure that you clean both scanning glasses, the one below and one above.

! CAUTION

Never spray mild detergent or water directly on the scanning glasses. The spray could penetrate below the glass, and contaminate the internal light source and lenses.

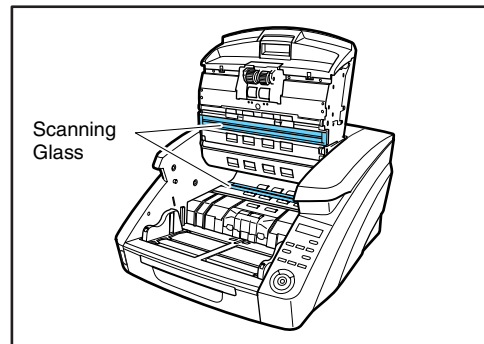

5. Wipe the rollers using a moistened and firmly wrung-out cloth while rotating the rollers.

The rollers are located at the positions indicated in the figure below.

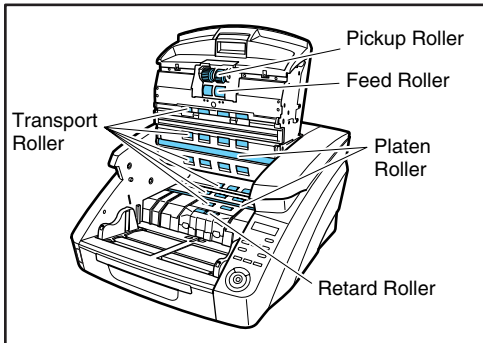

6. Remove the Pickup Roller, Feed Roller, and Retard Roller. (See “Removing and Reinstalling the Rollers” on p. 5-7.)

! IMPORTANT

Wipe the Pickup Roller, Feed Roller, and Retard Roller after removing them.

7. Wipe the rollers that you removed using a moistened and firmly wrung-out cloth.

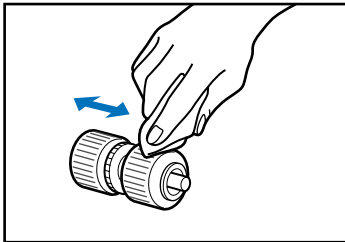

8. Replace the rollers that you removed. (See “Removing and Reinstalling the Rollers” on p. 5-7.)

9. Gently lower the upper unit (①). Press down on both sides of the upper unit to ensure that it is securely closed (②).

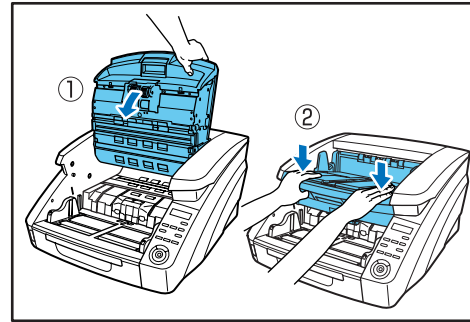

! IMPORTANT

If paper jams or double feeds occur frequently even after cleaning the rollers, the probable cause is the roller friction. If this happens, replace the rollers. Contact your service representative.

Power Outlet

If you leave the power plug connected to the power outlet for a long period of time, dust may accumulate at the power outlet, and cause a fire or electrical shock. Clean the power plug and power outlet regularly.

2. Replacing the Transport Rollers

As the rollers start to wear out, feeding quality declines, and document feed errors, such as paper jams, become more likely. If document feed errors continue to occur after cleaning the rollers, purchase the Roller Replacement Kit and replace the transport rollers (pickup, feed, and retard rollers).

Roller Replacement Cycle

The feeding rollers are consumables that must be replaced after feeding about every 250,000 pages. When the rollers have fed more than 250,000 pages, a roller replacement message appears on the display panel whenever the scanner is turned ON. When the scanner is configured to reboot with the computer, a roller replacement message also appears on the computer screen.

R e p l a c e R o l l e r

! IMPORTANT

- When the roller replacement message appears, purchase the Roller Replacement Kit and replace the rollers by following the relevant steps in the removing and reinstalling procedures.
 - (See “Removing and Reinstalling the Pickup Roller” on p. 5-7.)
 - (See “Removing and Reinstalling the Feed Roller” on p. 5-8.)
 - (See “Removing and Reinstalling the Retard Roller” on p. 5-10.)
- When the rollers start to wear out, problems such as paper jams and document misfeeds may occur more frequently. If this happens, replace the rollers, regardless of the page count of the roller usage counter.
- Messages on the display panel can be cleared by pressing the Count Clear key. However, the messages will continue to be displayed each time the scanner is turned ON until the roller counter is reset.
- Make sure to reset the roller counter when replacing the rollers. (See “Checking and Resetting the Page Counter” on p. 5-5.)

■ Roller Replacement Kit

The Roller Replacement Kit consists of replacement pickup, feed, and retard rollers. For details, contact your local authorized Canon dealer or service representative.

Product Name: Roller Replacement Kit

Product Code: 4009B001

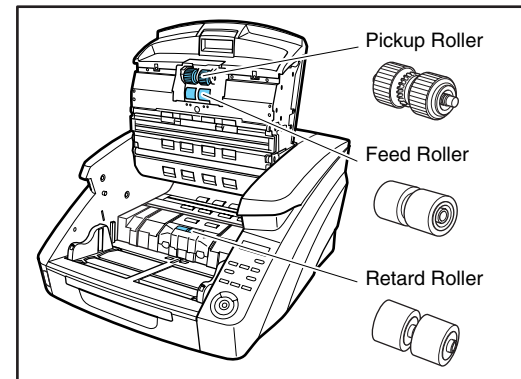

Checking and Resetting the Page Counter

The roller usage counter can be checked and reset using the Roller Counter in the User Mode setting.

! IMPORTANT

- This counter shows the number of pages transported by the currently installed feed rollers. Make sure to reset the counter when you replace the rollers.
- The Total Counter shows the total number of pages fed over the life of the scanner, and cannot be reset.

1. Press the Menu key on the control panel to activate the User Mode.

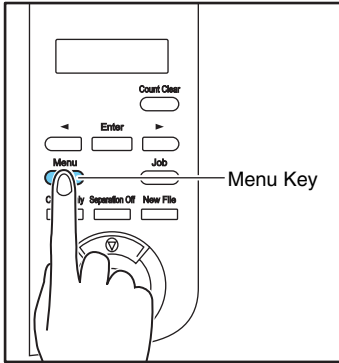

2. Press the [◀] key twice to display [Roller Counter].



3. Check the number of pages fed by the rollers, and press [Enter].

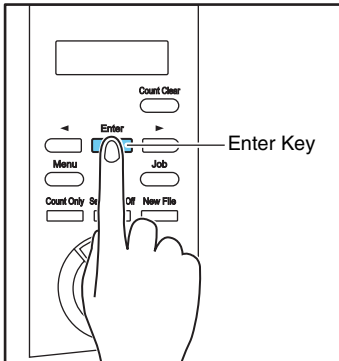

The counter reset mode is activated.



4. Press the [◀] key to select [RESET], and press [Enter].

The counter is reset to zero.



5. Press the [Stop] key to exit the User Mode.

Removing and Reinstalling the Rollers

Follow the procedure shown below to remove and reinstall the rollers when you need to clean or replace the Pickup, Feed, or Retard Rollers.

⚠ CAUTION

- Turn OFF the power switch, and disconnect the power plug from the power outlet when you remove or reinstall the rollers. Leaving the power turned ON may result in an electric shock.
- Do not place excessive force on the rollers when removing or reinstalling the rollers. Deformation of the rollers may cause feed errors.

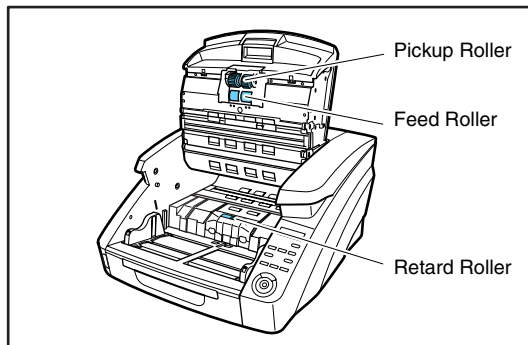

■ Removing and Reinstalling the Pickup Roller

1. Press the Open/Close button and carefully raise the upper unit until it stops.

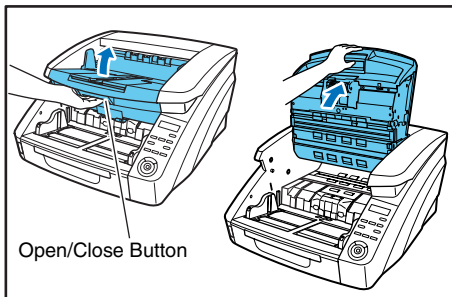

2. Open the roller cover.

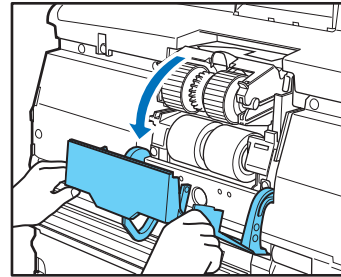

3. Open the roller holder.

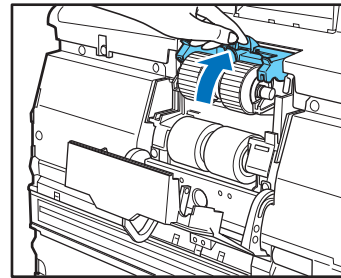

💡 Hint

The roller holder returns to its original position when released.

4. Remove the pickup roller.

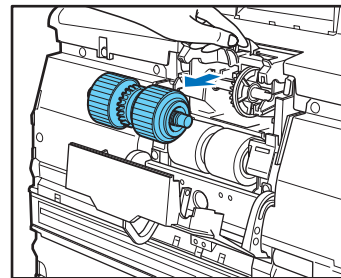

5. Open the roller holder, and insert the new pickup roller.

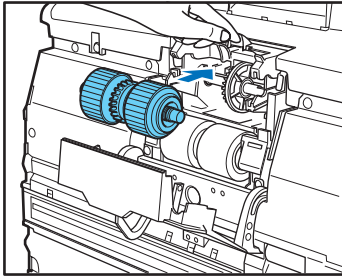

! IMPORTANT

Install the Pickup Roller so that side with the gear is on the left.

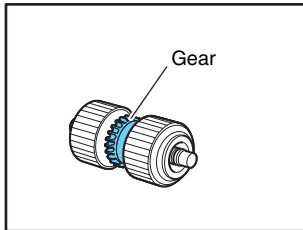

6. Close the roller cover. Check that it makes a latching sound and that it is securely returned to its original position.

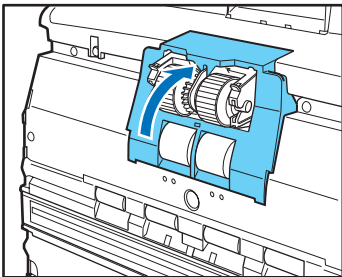

! IMPORTANT

Failure to firmly close the roller holder and roller cover may cause a feed error. Always be sure to check that the roller holder and roller cover are closed.

7. Gently lower the upper unit (①). Press down on both sides of the upper unit to ensure that it is securely closed (②).

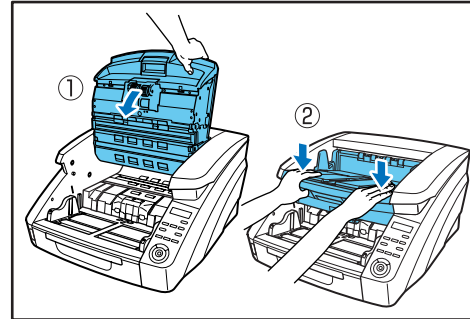

■ Removing and Reinstalling the Feed Roller

1. Press the Open/Close button and carefully raise the upper unit until it stops.

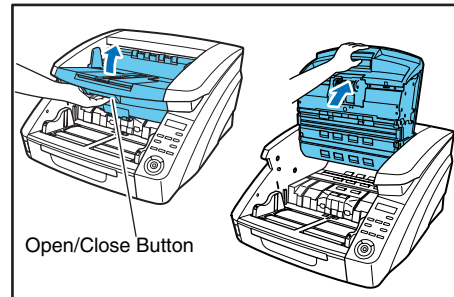

2. Open the roller cover.

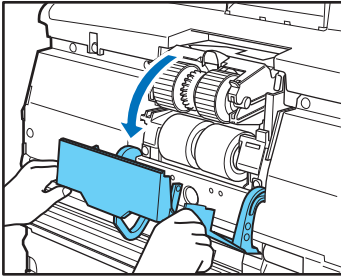

3. Pull the roller lock lever down.

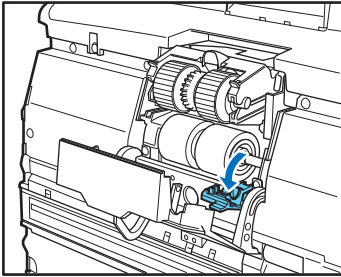

4. Slide the feed roller to the right, and then pull them towards you.

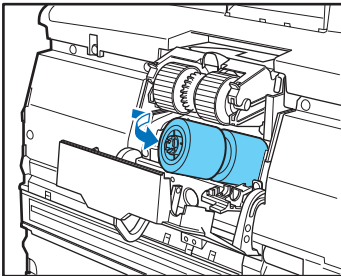

5. Remove the feed roller.

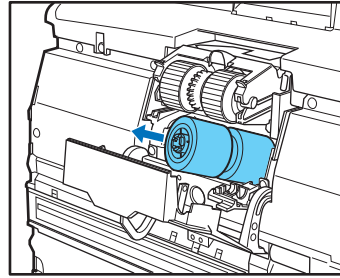

6. Place the new feed roller on the pin.

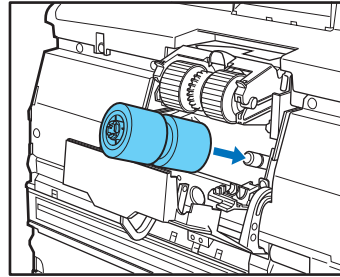

7. Put the feed roller in place (①), and align the notch in the roller's axle with the shaft on the scanner (②).

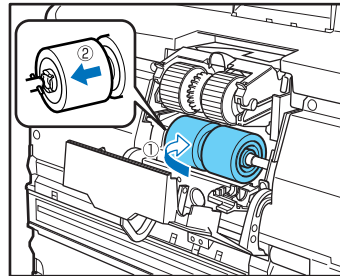

8. Push the roller lock lever up to lock the feed roller.

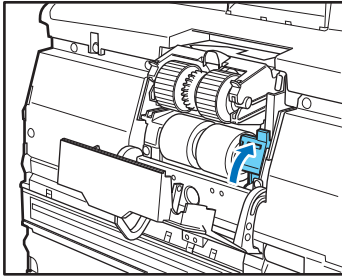

9. Close the roller cover. Check that it makes a latching sound and that it is securely returned to its original position.

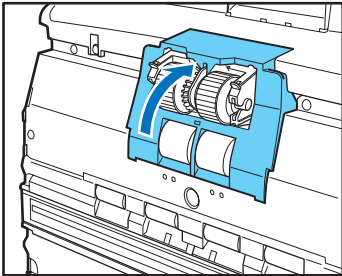

! IMPORTANT

Failure to firmly close the roller cover may cause a feed error. Always be sure to check that the roller cover is closed.

10. Gently lower the upper unit (①). Press down on both sides of the upper unit to ensure that it is securely closed (②).

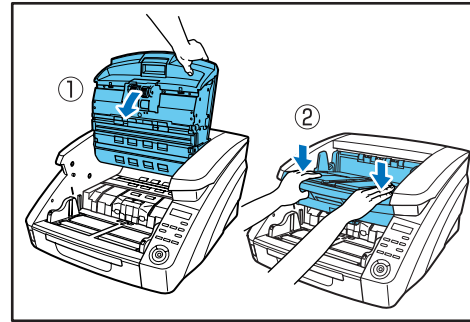

■ **Removing and Reinstalling the Retard Roller**

1. Press the Open/Close button and carefully raise the upper unit until it stops.

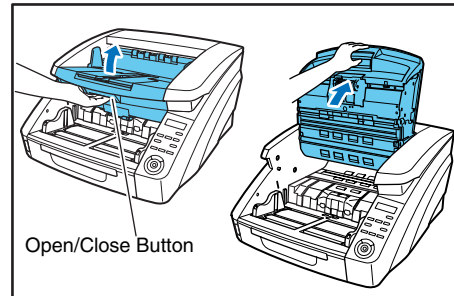

2. Grasp the roller cover with your fingers, and pull it up to remove it.

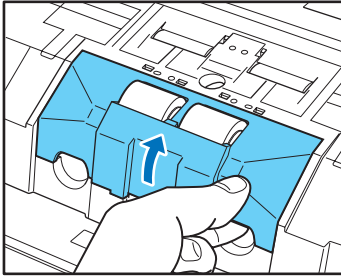

3. Push the roller lock lever up (1) and move it to the left (2) to unlock the roller.

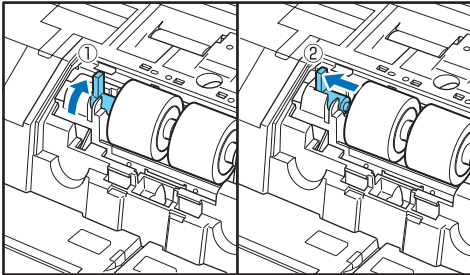

4. Remove the retard roller.

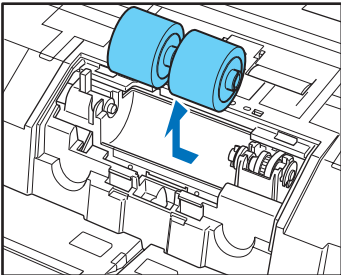

5. Set the retard roller into place in the scanner.

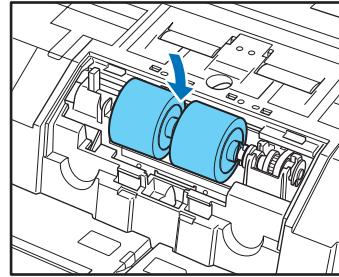

6. Align the notches in the roller with the shaft pins in the scanner, then slide the roller lock lever in the direction indicated by the arrow.

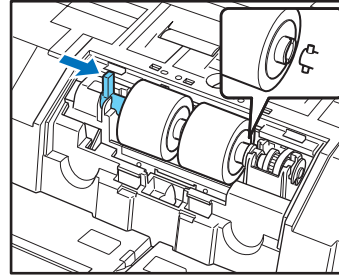

7. Pull the roller lock lever down to lock the retard roller in place.

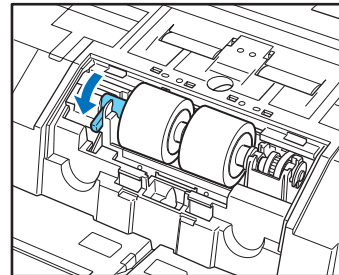

8. Replace the roller cover.

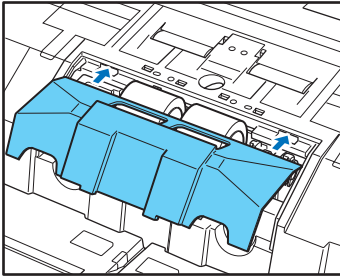

9. Push the front of the roller cover in. Check that it makes a latching sound and that it is securely returned to its original position.

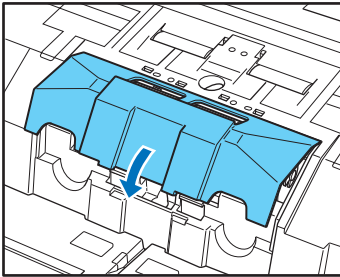

10. Gently lower the upper unit (1). Press down on both sides of the upper unit to ensure that it is securely closed (2).

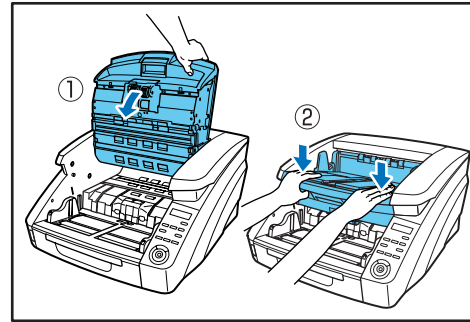

⚠ CAUTION

Make sure that the hook is completely latched and the roller cover is not loose. If the roller cover is loose, the Document Feed Tray will catch on it causing the scanner to malfunction.

3. Imprinter Ink Cartridge Replacement and Cleaning

When the optional imprinter is used, printing will become faint or nonexistent when the ink is depleted. It is recommended to keep a spare ink cartridge on hand.

About the Imprinter

The ink cartridge for the imprinter that prints on scanned documents is installed in the following location.

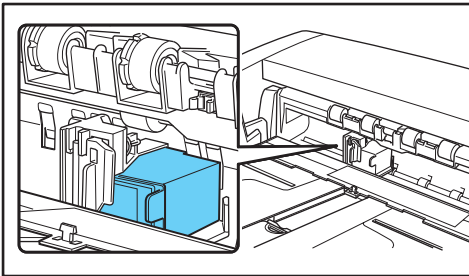

■ Preparing an Ink Cartridge

Use one of the following red, blue or green HP ink cartridges. For details, contact your local authorized Canon dealer or service representative.

Product Name: Ink Cartridge (Blue)

Product Code: 3693A002

Product Name: Ink Cartridge (Red)

Product Code: 3693A003

Product Name: Ink Cartridge (Green)

Product Code: 3693A004

Replacing Ink Cartridges

Replace the ink cartridge using the following procedure.

! IMPORTANT

After replacing an ink cartridge, run a test print to confirm proper printing. (See "Imprinter Testing" on p. 5-17.)

1. Spread the document guides all the way to the left and right.
2. With your finger, push in the area of the imprinter cover shown by the arrow to release it.
The imprinter cover unlocks and opens to the front.

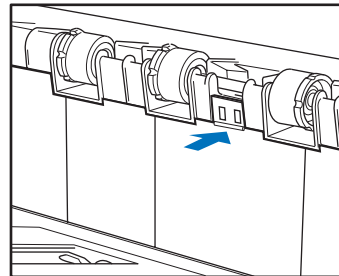

3. Open the imprinter cover until it makes contact with the eject tray.

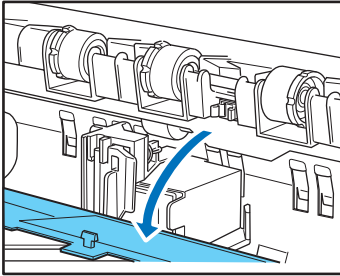

 **Hint**

Perform the steps that follow with the imprinter cover fully open.

4. Pull the lock lever outward (①) to release the ink cartridge lock (②).

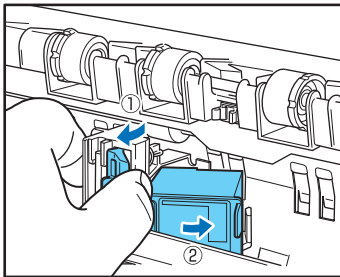

5. Remove the ink cartridge.

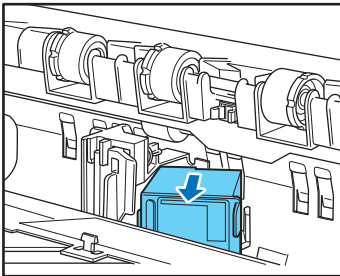

6. Peel off the seal covering the nozzles of a new ink cartridge.

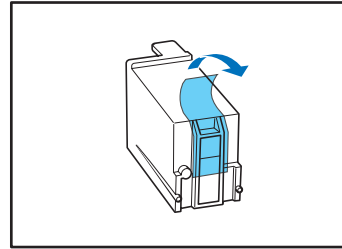

 **CAUTION**

Peel off the seal covering the nozzles of a cartridge only if you are going to use it immediately. Also, avoid touching the metal contacts or nozzles of the ink cartridge.

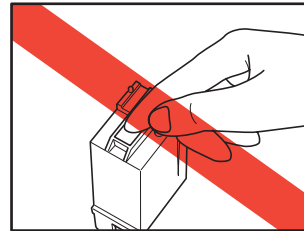

7. Install the new cartridge with the nozzles facing to the right.

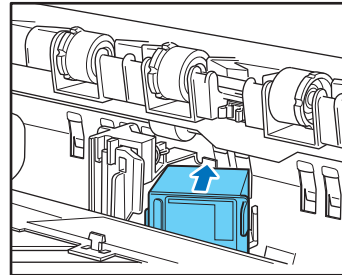

8. Push the ink cartridge as indicated by the arrow until it clicks into place.

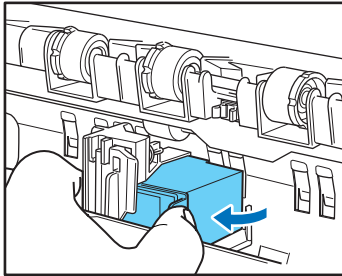

9. Adjust the carriage position by moving it left or right, then make sure you can feel it click in. (See “Specifying the Printing Position” on p. 5-15.)

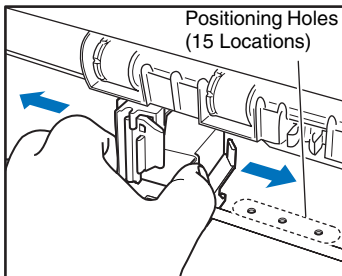

 **Hint**

If you do not feel it click in, the carriage is not aligned correctly with a positioning hole. Always move the carriage to a position where it clicks in.

10. Close the imprinter cover.

With your finger, push in the area of the imprinter cover shown by the arrow to lock it.

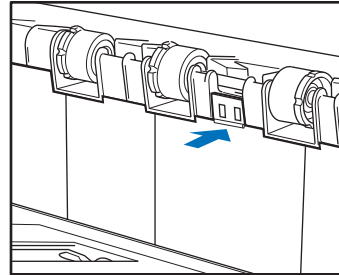

 **Hint**

The imprinter cover will not close unless the carriage is correctly aligned with a positioning hole. If it will not close, check the position of the carriage.

 **IMPORTANT**

When closing the imprinter cover, make sure that it is locked so that it will not open unexpectedly. An error message appears on the display panel if the imprinter cover is open.

C o v e r O p e n

C 0 0 9

Specifying the Printing Position

Manually specify the printing position in the horizontal direction of the document.

To do this, move the carriage left or right and align it with one of the 15 positioning holes.

1. Roughly align the right edge of the lock lever with the desired printing position.

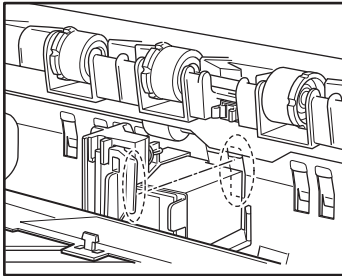

 **Hint**

The position of the right edge of the lock lever indicates the current printing position.

2. Finely adjust the carriage position by moving it left or right, then make sure you can feel it click in.

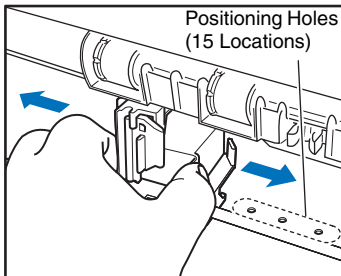

 **Hint**

- If you do not feel it click in, the carriage is not aligned correctly with a positioning hole. Always move the carriage to a position where it clicks in.
- The imprinter cover will not close unless the carriage is correctly aligned with a positioning hole. If it will not close, check the position of the carriage.

Cleaning the Imprinter

■ Cleaning the Guide Plate

Ink that collects on the guide plate inside the optional imprinter may stain the documents when they are scanned. Clean off the ink with water and a mild detergent on a soft cloth that has been firmly wrung-out, and then thoroughly dry it with a dry cloth.

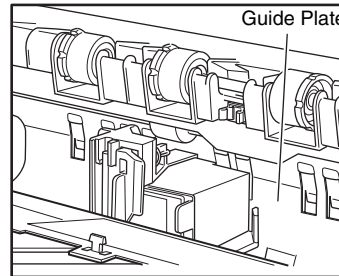

■ Cleaning the Ink Cartridges

If the imprinter print head nozzles are dirty, printing may become streaked or spotty. To prevent this, periodically remove the ink cartridge and clean the print head with a soft, dry cloth or cotton swab.

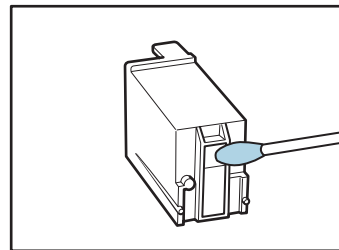

⚠ CAUTION

Do not touch the metal contacts on the ink cartridge. Doing so may cause poor connections, resulting in poor print quality.

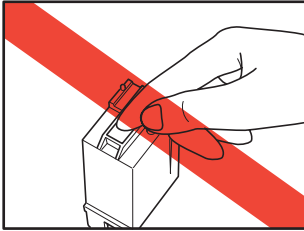
**Imprinter Testing**

After replacing an ink cartridge or cleaning the print head, perform a test print to confirm proper printing. Test printing is performed by the “Imprinter Test” User Mode selection.

! IMPORTANT

Before performing an Imprinter Test, load a sheet of paper into the Document Feed Tray.

■ Performing an Imprinter Test

Use the following procedure to execute the Imprinter Test.

1. Load a sheet of paper into the Document Feed Tray for test printing.

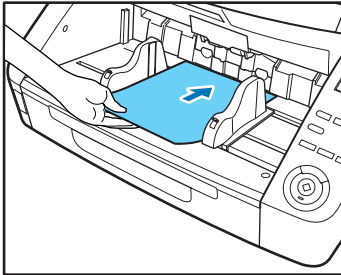

2. Press the Menu key on the control panel.

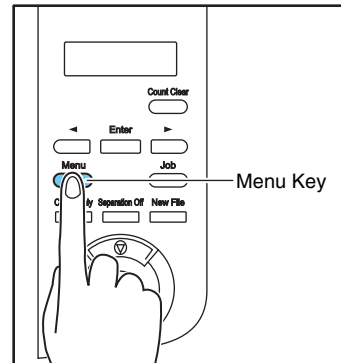

The User Mode is activated.

```
B u z z e r   C o n t r o l
[ O N 2 ]   O N 1   O F F
```

3. Press the [◀] key once to display “Imprinter Test”.

```
I m p r i n t e r   T e s t
```

4. Press [Enter].

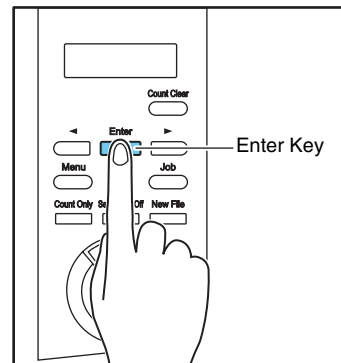

The Imprinter Test is enabled.



5. Press the [◀] key to select [OK], and press [Enter].
The test print is executed.

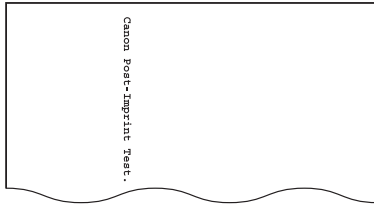

! IMPORTANT

If no paper is loaded for test printing, the imprinter test finishes without printing.

6. Press the [Stop] key to exit the User Mode.

Chapter 6 Practical Examples

1. Messages	6-2
Status Display	6-2
Error Messages	6-3
2. Troubleshooting	6-5
Trouble Categories.....	6-5
Problem and Solution.....	6-5
3. Uninstalling the Software	6-9
Uninstalling the ISIS/TWAIN Driver.....	6-9

1. Messages

There are two types of display panel messages: “status indicator messages” and “error messages” that appear when the scanner encounters a problem.

Status Display

The following messages appear on the display panel to indicate the scanner’s operating state:

■ Counting...

```
Counting . . .
                X X X X X
```

Status: Operating in Count-Only mode.

■ Press Start Key

```
Press Start Key
```

Status: Waiting. Load a document and press the Start key.

■ Ready

```
Ready
                0 0 0 0 0
```

Status: The scanner is ready to use.

■ Scanning...

```
Scanning . . .
                X X X X X
```

Status: Scanning is in progress.

■ Sleeping...

```
Sleeping . . .
```

Status: The scanner is entering the Sleep mode. Press any key to recover.

■ Please wait...

```
Please wait . . .
```

Status: The scanner is busy processing. Wait until the display changes.

■ Verifying...

```
Verifying . . .
                X X X X X
```

Status: The scanner is verifying a scan.

■ Replace Roller

```
Replace Roller
```

Status: It is time to replace the rollers (the number of fed pages has exceeded 250,000). (See “Roller Replacement Cycle” on p. 5-5.)

Error Messages

When one of the following messages appears on the display panel, an error has occurred in the scanner. Follow the indicated procedure to resolve the error.

■ Check Imprinter

```
C h e c k   I m p r i n t e r
                               H 0 0 1
```

Error Code: H001

Problem: No ink cartridge is installed in the imprinter.

Solution: Install an ink cartridge.

■ Cover Open

```
C o v e r   O p e n
                               C 0 0 1
```

Error Code: C001

Problem: The scanner's upper unit is open.

Solution: Close (lower) the upper unit. (See p. 5-4.)

Error Code: C009

Problem: The imprinter cover is open.

Solution: Close the imprinter cover. (See p. 5-15.)

Error Code: C010

Problem: The pickup roller cover is open.

Solution: Close the pickup roller cover. (See p. 5-8.)

■ Jam

```
J a m
                               P 0 0 1
```

Error Code: Pxxx

Problem: Paper has jammed.

Solution: Open the upper unit and remove the jammed paper. (See p. 3-23.)

Hint

The displayed error code indicates the location of the paper jam.

- P001, P002: The document is jammed near the feed inlet.
- P004: The document is jammed inside the scanner.
- P006, P007: The document is jammed near the eject outlet.
- * P001, P006 can be considered to be due to the document feed speed being too fast or the leading edge of the document not feeding correctly.

■ Call for Service

```
C a l l   f o r   S e r v i c e
                               E 0 0 0
```

Error Code: Exxx

Problem: Internal scanner error.

Solution: Turn the power OFF, and restart the scanner. If this does not solve the problem, make a note of the error code, and contact your Canon service representative.

■ Skew Detected

```
S k e w   D e t e c t e d
                               J 0 1 8
```

Error Code: J018

Problem: A skewed document page contacted the wall of the transport path.

Solution: Remove and reposition the document page.

■ Double Feed

```

D B L   F e e d
                                D 0 0 4
  
```

Error Code: D002

Problem: A double feed was detected by the document length.

Solution: Remove the double fed document page(s), return them to the Document Feed Tray, and scan again.

(See p. 3-24.)

Error Code: D004

Problem: A double feed was detected ultrasonically.

Solution: Remove the double fed document page(s), return them to the Document Feed Tray, and scan again.

(See p. 3-24.)

■ Double Feed (Rapid Recovery System)

```

D B L   F e e d
[ I G N O R E ] R E T R Y
  
```

Problem: Double feeding of document pages has been detected while scanning with the Rapid Recovery System enabled.

Solution: Remove the double fed document page(s), return them to the Document Feed Tray, and scan again.

(See p. 3-24.)

■ Staple Detected

```

S t a p l e   D e t e c t e d
                                J 0 0 1
  
```

Error Code: J001

Problem: A stapled document has been detected.

Solution: Remove the staple(s), and rescan the document.

■ Tray Error

```

T r a y   E r r o r
                                E 0 2 1
  
```

Error Code: E021

Problem: An error has occurred with the Document Feed Tray.

Solution: Turn the power OFF, and restart the scanner.

■ Count Mismatch

```

C o u n t   M i s m a t c h
                                U 0 0 1
  
```

Error Code: U001

Problem: The specified count has not yet been reached.

Solution: Check the document count, and scan again.

Error Code: U002

Problem: Scanning finished without reaching the specified count.

Solution: Check the document count, and scan again.

2. Troubleshooting

This section describes the problems that may occur during use of the scanner and how to solve them.

Trouble Categories

The following trouble categories are addressed:

- [The Scanner Does Not Turn ON \(See p. 6-5\)](#)
- [The Scanner Is Not Recognized \(Connecting via USB\) \(See p. 6-5\)](#)
- [The Scanner Is Not Recognized \(Connecting via SCSI\) \(See p. 6-5\)](#)
- [Scanning Is Not Performed \(See p. 6-6\)](#)
- [Slow Scanning Speed \(See p. 6-6\)](#)
- [Documents Do Not Feed Properly \(See p. 6-7\)](#)
- [Saved Image Files Do Not Open \(See p. 6-7\)](#)
- [Scanning Results Are Not as Expected \(See p. 6-7\)](#)

If you cannot resolve a problem, contact your local authorized Canon dealer or your service representative.

Problem and Solution

■ The Scanner Does Not Turn ON

If the scanner does not turn ON, first confirm the following:

- ✓ Is the power cord connected correctly?
- ✓ Is the power cord inserted into the power outlet?

■ The Scanner Is Not Recognized (Connecting via USB)

If the scanner's USB connection is not recognized, first confirm the following:

- ✓ Are the scanner and PC connected correctly using the proper cable?
- ✓ Is the scanner's power switch turned ON?

If this does not solve the problem, consider the following possible causes:

Cause	The scanner does not support your USB interface.
-------	--

Solution	This product is not guaranteed to operate with all types of USB interfaces. Contact your local authorized Canon dealer or service representative for more information.
----------	--

Cause	The scanner does not support the USB cable.
-------	---

Solution	Use the USB cable provided with the scanner.
----------	--

Cause	The USB hub is not compatible with the scanner.
-------	---

Solution	Remove the USB hub.
----------	---------------------

■ The Scanner Is Not Recognized (Connecting via SCSI)

If the scanner's SCSI connection is not recognized, first confirm the following:

- ✓ Are the scanner and PC connected correctly using the proper cable?
- ✓ Is the scanner's power switch turned ON?
- ✓ Is the SCSI card in the PC operating properly?
- ✓ Was the PC turned ON before the scanner?

! IMPORTANT

When using the SCSI connection, if the scanner is turned ON after the PC, it may not be properly recognized by the PC.

If this does not solve the problem, consider the following possible causes:

Cause	The SCSI card is not compatible with the scanner.
-------	---

Solution	Use a recommended SCSI card. (See p. 2-3.)
----------	--

Cause	The scanner's SCSI ID is identical to the SCSI ID of another device.
-------	--

Solution	Check the SCSI IDs of all SCSI devices connected to the system and set a unique SCSI ID for the scanner.
----------	--

Cause	The terminator is not set correctly.
-------	--------------------------------------

Solution	When another SCSI device is connected between the scanner and the PC, that device's terminator must be disabled (set to OFF).
----------	---

Cause	There is a problem with another SCSI device that is connected in the daisy chain.
-------	---

Solution	Do not use the daisy chain connection configuration.
----------	--

■ Scanning Is Not Performed

If scanning does not start when it should, first confirm the following:

- ✓ Are the scanner and PC correctly connected with the proper cable?
- ✓ Is the scanner's power switch turned ON?

If this does not solve the problem, consider the following possible causes:

Cause	The ISIS/TWAIN driver and Job Registration Tool are not installed correctly.
-------	--

Solution	Uninstall and then reinstall the ISIS/TWAIN driver and Job Registration Tool.
----------	---

! IMPORTANT

- If the scanner does not operate because of a system error, turn the scanner OFF and wait at least 10 seconds before turning it back ON. If errors continue to occur, reboot the scanner and computer.
- When scanning with configurations that use a large amount of the computer's memory, scanning will be performed properly for the first scan. However, if a second scan is performed with the same configurations, an error may occur due to insufficient memory and scanning may not be possible. In such cases, restart the application you are using and change the configurations before scanning again.

■ Slow Scanning Speed

If the scanning speed is slow, first confirm the following: Scanning may be slow if the USB interface does not support Hi-Speed USB 2.0.

- ✓ Does the PC's USB interface support only Full-Speed USB 1.1?
- ✓ Is the USB cable you are using the one that was supplied with the scanner (Hi-Speed USB 2.0 compliant)?
- ✓ Is a USB 1.1-compliant device connected to the USB hub at the same time?

If this does not solve the problem, consider the following possible causes:

Cause	Other applications are running in the background on your PC.
-------	--

Solution	Quit all other applications that are running.
----------	---

Cause	Resident applications, such as anti-virus software, are draining memory resources.
-------	--

Solution	Quit all resident applications.
----------	---------------------------------

Cause	Temporary files cannot be created in the TEMP folder, as there is not enough free space on the hard disk.
-------	---

Solution	Delete unnecessary files on the hard disk to increase free space.
----------	---

■ Documents Do Not Feed Properly

If a document does not feed properly, first confirm the following:

- ✓ Are pages sticking together because of static electricity or another cause?
- ✓ Are you attempting to scan a document with size, paper thickness or quality that is not supported by the scanner? (See “Documents” on p. 3-3.)
- ✓ Are the feed rollers dirty?
- ✓ Are the feed rollers worn out?

! IMPORTANT

- Double feeding occurs when document pages stick together, and incompatible paper thickness or quality can cause paper jams. Check your documents carefully before loading.
- Replacement rollers can be purchased as consumables. If performance is not improved after cleaning the rollers, contact your local Canon dealer or service representative to purchase a Roller Replacement Kit, and replace the rollers (pickup, feed and retard rollers). (See “Replacing the Transport Rollers” on p. 5-5.)

If this does not solve the problem, consider the following possible problems and causes:

Problem	Documents do not feed.
Cause	The Continuous Manual Feed Mode is enabled.
Solution	Set the Continuous Manual Feed Mode to [OFF] from the User Mode. (See “Continuous Manual Feeding Mode Setting” on p. 3-12.)

■ Saved Image Files Do Not Open

If image files saved by CapturePerfect 3.0 cannot be opened by another application, first confirm the following:

- ✓ Does the application you are using support CapturePerfect 3.0 image file types (*.bmp, *.tif, *.jpg and *.pdf)?

If this does not solve the problem, consider the following possible causes:

Cause	The application does not support multi-page TIFF files.
Solution	Open the files using an application that supports multi-page TIFF files, or save the images as single-page TIFF files using CapturePerfect 3.0.
Cause	The compression format used by CapturePerfect 3.0 is not supported.
Solution	Open the image file with CapturePerfect 3.0, set the compression format to [None], and save it again.

■ Scanning Results Are Not as Expected

If the scanned images do not appear as expected, one or more ISIS/TWAIN driver settings may be incorrect, or your application may not support certain scanner functions.

Problem	The scanned image is too dark (or faint).
Cause	The [Brightness] setting is not set to an appropriate value.
Solution	If the image is too dark, set a higher brightness setting, or if the image is too faint, set a lower brightness setting.

Problem	Text or images from the back side of your document appear in the scanned image.
Cause	Brightness may be set too low.
Solution	Increase the Brightness setting. Or, enable the [Prevent Bleed Through/Remove Background] setting.
Cause	The paper is too thin.
Solution	Photocopy the document, and scan the copy.

Problem	Double-sided scanning is not possible.
Cause	Scanning Side is set to [Simplex].
Solution	Set Scanning Side to [Duplex]. If the Scanning Side is set to [Skip blank page], images of blank pages are not saved.

Problem	A black margin appears around the scanned document.
Cause	A document smaller than the preset paper size has been scanned. Or, the loaded document has shifted out of position.
Solution	Choose one of the following: (1) Set [Page size] to [Auto-detection]. (2) Adjust the margin setting in a single direction. (3) Enable Border Removal.

Problem	The scanned image is skewed. (skew)
Cause	The document has been fed at an angle.
Solution	Slide the document guides to fit the width of your document.

Problem	Lines, smudges, or dirt appear on the scanned image.
Cause	The scanning glass or rollers inside the scanner are dirty.
Solution	Clean the scanning glass and rollers. (See “Regular Maintenance” on p. 5-2.) If lines still appear on the image even after you clean the scanning glass and rollers, the scanning glass inside the scanner may be scratched. Contact your local authorized Canon dealer or service representative.

Problem	The scanned image is abnormal for certain documents.
Cause	A detection function such as border removal is enabled when scanning a document that includes text or photos extending to the edge of the page (the scanner cannot accurately process the edges of documents).
Solution	When a page has text or photos extending to its edges, turn the detection functions off or scan that page individually.

Problem	The scanned image is abnormal in some applications.
Cause	A function not supported by the application was used.
Solution	Some applications do not support functions such as auto-detection of page size, so scanning with such applications will produce abnormal scanned images. If abnormal image appearance seems to be application-dependent, try scanning with auto-detection disabled.

3. Uninstalling the Software

Some scanner malfunctions can be resolved by reinstalling the software. Before reinstalling the software, make sure to completely uninstall any previous installation first.

Uninstalling the ISIS/TWAIN Driver

The following procedure uses the ISIS/TWAIN driver as an example. Follow the same procedure to uninstall the Job Registration Tool and CapturePerfect 3.0. Make sure to substitute the name of the software in step 3.

! IMPORTANT

As always when uninstalling software, log on using an account with Administrator privileges.

💡 Hint

This section describes the operations by using Windows Vista as an example.

1. Click the [Start] button, then click [Control Panel].

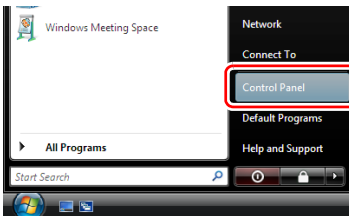

The Control Panel appears.

2. Click [Uninstall a program].

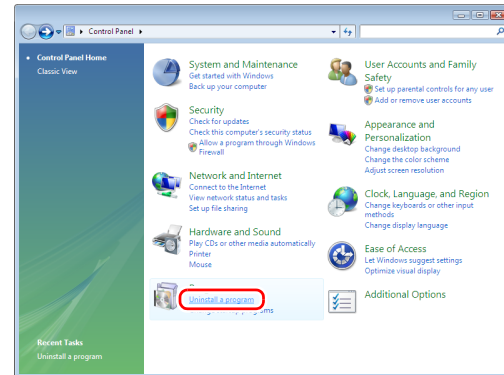

3. From the program list, select the application to be removed and click the [Uninstall] button.

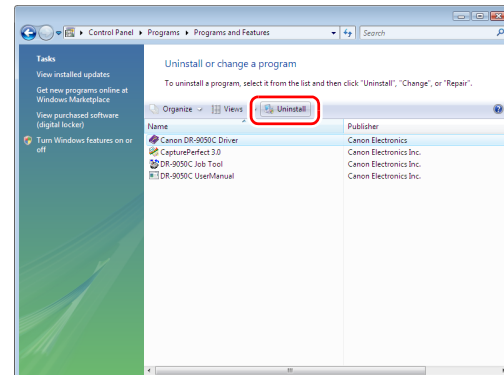

The "User Account Control" dialog box appears.

4. Click the [Continue] button.

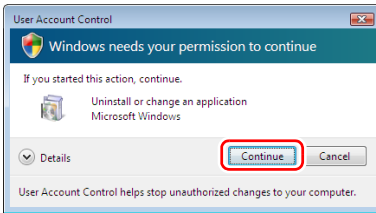

The file-deletion confirmation screen appears.

5. Click [Yes] to proceed with uninstallation.

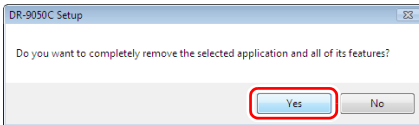

6. When uninstallation is finished, click [Finish].

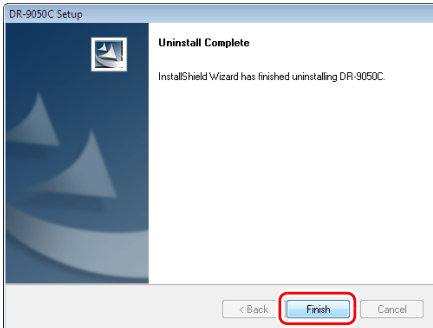

Chapter 7 Appendix

1. Specifications.....	7-2
Unit Specifications.....	7-2
Options.....	7-3
Consumables	7-3
External Dimensions	7-4
2. Option Specifications.....	7-5
Barcode Specifications.....	7-5
Imprinter Specifications.....	7-6
3. Index.....	7-7

1. Specifications

Unit Specifications

Type

Desktop sheet-fed scanner

Scannable Document Requirements

Width: 2" to 12.01" (50.8 mm to 305 mm)

Length: 2.76" to 17.01" (70 mm to 432 mm)

Weight: Continuous Feeding: 14 lb to 56 lb bond
(52 g/m² to 209 g/m²) (0.06 mm to 0.25 mm)
Manual Feeding: 11 lb to 64 lb bond (42 g/m²
to 255 g/m²) (0.05 mm to 0.30 mm)

Document Feeding Methods

Continuous, Manual, and Continuous Manual

Document Feeder Capacity

DR-6050C:

Up to 300 sheets of good quality paper or up to
1.10" (28 mm) high (maximum)

DR-7550C/9050C:

Up to 500 sheets of good quality paper or up to
1.89" (48 mm) high (maximum)

Scanning Sensor

Contact image sensor

Light Source

LED

Scanning Sides

Simplex/Duplex/Skip blank page

Scanning Modes

Black and White, Error Diffusion, Advanced Text
Enhancement, Advanced Text Enhancement II, 256-
Level Grayscale, and 24-Bit Color

Scanning Resolution

100, 150, 200, 240, 300, 400 and 600 dpi

Scanning Speed (LTR/A4 portrait)

Black and White

	DR-6050C	DR-7550C	DR-9050C
Simplex 200 dpi	60 pages/min.	75 pages/min.	90 pages/min.
Simplex 300 dpi	60 pages/min.	75 pages/min.	90 pages/min.
Duplex 200 dpi	120 images/min.	150 images/min.	180 images/min.
Duplex 300 dpi	120 images/min.	150 images/min.	180 images/min.

Grayscale

	DR-6050C	DR-7550C	DR-9050C
Simplex 200 dpi	60 pages/min.	75 pages/min.	90 pages/min.
Simplex 300 dpi	60 pages/min.	75 pages/min.	90 pages/min.
Duplex 200 dpi	120 images/min.	150 images/min.	180 images/min.
Duplex 300 dpi	120 images/min.	150 images/min.	180 images/min.

Color

	DR-6050C	DR-7550C	DR-9050C
Simplex 200 dpi	60 pages/min.	75 pages/min.	90 pages/min.
Simplex 300 dpi	60 pages/min.	75 pages/min.	90 pages/min.
Duplex 200 dpi	120 images/min.	150 images/min.	180 images/min.
Duplex 300 dpi	120 images/min.	150 images/min.	170 images/min.

Other

Double-Feed Detection, Deskew, User Mode, Long
Document Mode, and Folio Scan

External Dimensions

18.90" (W) × 20.91" (D) × 12.24" (H)

480 mm (W) × 531 mm (D) × 311 mm (H)

Maximum External Dimensions (with Document Feeder

Tray Extension / Extension Wire, and Document Eject

Tray Extension / Eject Paper Stoppers open)

18.90" (W) × 28.27" (D) × 15.35" (H)

480 mm (W) × 718 mm (D) × 390 mm (H)

Weight

Approx. 50 lbs (22.5 kg)

Power Supply

120 V model

AC 120 V (60 Hz), 1.4 A

220-240 V model

AC 220-240 V (50/60 Hz), 0.8 A

Power Consumption

120 V model

Scanning: 83 W

Stand-by Mode (Sleep Mode): 3.2 W

220-240 V model

Scanning: 84 W

Stand-by Mode (Sleep Mode): 3.9 W

Noise

Not more than 72 dB

Operating Environment

Temperature: 10 to 32.5°C (50 to 90.5°F)

Humidity: 20 to 80% RH

* Specifications are subject to change without notice.

Options**Imprinter Unit (Product Code: 4009B003)**

This imprinter unit prints a text string on document pages after scanning them. (See [“Imprinter \(Optional\)”](#) on p. 4-7.)

Barcode Module (Product Code: 8927A003)

Add-on software that enables barcode recognition by the ISIS/TWAIN driver. (See [“\[Barcode\] Dialog Box Settings”](#) on p. 8-22.)

Patchcode Decoder (Product Code: 4009B002)

This unit detects patchcode sheets within documents. (See [“Using Patchcode Sheets \(Option\)”](#) on p. 3-20.)

Consumables**Roller Replacement Kit (Product Code: 4009B001)**

Replacement kit for transport rollers (pick-up roller, feed rollers, and retard roller). (See [“Replacing the Transport Rollers”](#) on p. 5-5.)

! IMPORTANT

- Rollers are consumable parts. When the rollers start to wear out, problems, such as paper jams and misfeeds, are more likely to occur. If this happens, replace the rollers, regardless of the page count.
- For information about the roller replacement kit, contact your local authorized Canon dealer or service representative.

Ink Cartridge: Blue (Product Code: 3693A002)

This blue ink cartridge is used by the imprinter. (See [“Replacing Ink Cartridges”](#) on p. 5-13.)

Ink Cartridge: Red (Product Code: 3693A003)

This red ink cartridge is used by the imprinter.

Ink Cartridge: Green (Product Code: 3693A004)

This green ink cartridge is used by the imprinter.

External Dimensions

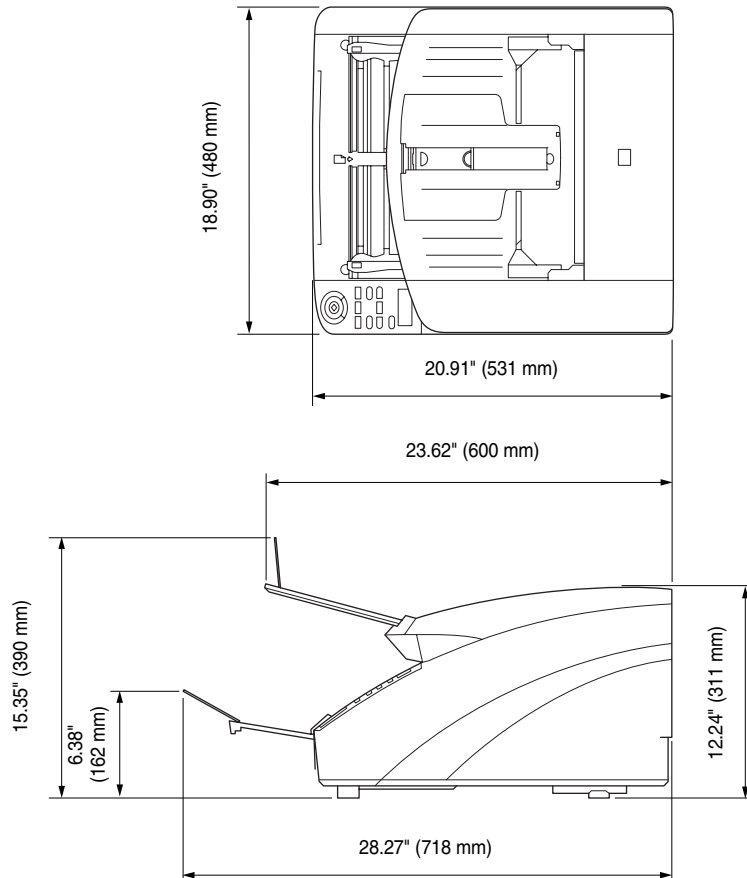

2. Option Specifications

This section contains the specifications for the separately sold Barcode Module (p. 7-3) and imprinters. Refer to “Using Patchcode Sheets (Option)” (p. 3-20) for the specifications of the patchcodes that can be detected by the patchcode decoder.

Barcode Specifications

The following barcodes can be read by installing the optional barcode module.

Barcode Types

Code	No. of Digits	Checksum
EAN	8 or 13	Modulus 10, Weight 3
Codabar	3 to 32 (including Start/Stop characters)	Modulus 16, 7 DR
Code 39	3 to 32 (including Start/Stop characters) (Standard ASCII or Full ASCII)	Modulus 43
ITF	2 to 32 (Even number. of digits only)	Modulus 10, Weight 3
Code 128	1 to 32 (Valid data only)	Modulus 103
UPC-A	13	Modulus 10, Weight 3
UPC-E	8	Modulus 10, Weight 3

Note: EAN, UPC-A and UPC-E add-ons supported

Detection Conditions

Item	Condition	
Printed Side	Front or back (or both, but at reduced speed)	
Orientation	Perpendicular (0 degrees) or parallel (90 degrees) to the feeding direction  Reading direction should be specified beforehand Note: Speed is slow when both directions are specified.	
Size	Line Width	0.012" to 0.039" (0.3 to 1 mm) When module width exceeds 0.021" (0.508 mm), Code 128, UPC-A, UPC-E and EAN detect incorrectly
	Code Width	4.134" (105 mm) or less (including quiet zone)
	Bar Height	At least 0.393" (10 mm)
	Margins	At least one character at each end
Slew	Within $\pm 3^\circ$	
Element Ratio	2.2 to 3.0	
PCS Value	At least 0.60 (with a white point of at least 75% reflectance)	

Item	Condition	
Position	Feeding Direction	At least 0.079" (2 mm) from the edge of the page
	Perpendicular to Feeding Direction	At least 0.197" (5 mm) from the edge of the page
Quantity	Up to four per page	
Spacing	At least 0.197" (5 mm)	
Conditions	No background or overlapping barcodes	

Imprinter Specifications

Printing Side

Front

Position

Set in the ISIS/TWAIN driver ([See p. 8-26](#))

One of 15 positions

Printing Content

Set in the ISIS/TWAIN driver

Imprinter Font Sizes (Dots)

12 × 12 (with no added space between characters)

12 × 8 (with no added space between characters)

12 × 12 (with added space between characters)

12 × 8 (with added space between characters)

Number of Printable Characters

Up to 32 characters

Printable Paper

Plain paper without water-resist coating

Compatible Ink Cartridges

HP Ink Cartridges

Color: Blue, Red, Green ([see p. 5-13](#))

Image Density

12 nozzles/oblique line (96 dpi)

Ink Type

Water-based

3. Index

C

CapturePerfect 3.0	3-15
Cleaning	
glass	5-3
power outlet	5-4
print heads	5-16
rollers	5-3
scanner	5-2
sensors	5-2
Cleaning Cloth	5-2
Connecting to a Computer	2-6
Control Panel	1-12
Counter	5-5
Count-Only Mode	4-4

D

Daisy-Chain Configuration	2-8
Device Manager	2-10
Disposal	1-5
Document Eject Tray	3-10
extension	3-10
Document Feed Tray	3-6
extension	3-7
tray position	3-6
Document Feeding Methods	3-11
continuous feeding	3-11
continuous manual feeding	3-12
manual feeding	3-11
Document Guides	3-7, 3-10
adjusting	3-10
Documents	3-3
Double-Feed Detection	4-5
Double-Feed Errors	3-24

E

Eject Paper Stoppers	3-10
Error Messages	6-3

F

Folio Scanning	4-6
----------------------	-----

H

Handling	1-3
----------------	-----

I

Imprinter	4-7, 5-13
Imprinter Testing	5-17
Ink Cartridges	5-13
Installation Location	1-2

J

Job Function	3-14
--------------------	------

L

Long Document Mode	3-4
--------------------------	-----

M

Maintenance	5-2
Manuals	iii
Messages	6-2
Moving the Scanner	1-3

O

Other Functions	4-2
-----------------------	-----

P

Paper Jams	3-23
Part Names and Functions	1-10
Patchcode Patterns	3-20
Patchcode Sheets	3-20
Power	1-2
turning ON/OFF	3-2
Power Switch	2-9, 3-2
Preface	iii
Problems and Solutions	6-5

R

Rapid Recovery System	3-25
Replacing Ink Cartridges	5-13
Replacing the Transport Rollers	5-5
replacement cycle	5-5
Roller Replacement Kit	5-5

S

Safety Instructions	1-2
Scanner Recognition	2-9
Scanning	3-14
SCSI Connection	2-7
SCSI Connector	2-6
Setup	2-2
Setup Menu	2-4
custom installation	2-4
read manuals	2-5
typical installation	2-4
Skew Detection	4-6
Software	
installing	2-4
uninstalling	6-9
Staple Detection	4-6
Status Display	6-2
System Requirements	2-3

T

Terminator	2-8
Troubleshooting	6-5
trouble categories	6-5

U

Ultrasonic Double-Feed Detection	4-5
USB Connection	2-6
USB Connector	2-6
User Mode	4-8
functions	4-10
operating procedure	4-8

V

Verify Count	4-4
Verify Scan	4-4

User Manual

Software

Please read this manual before using the scanner.
After you finish reading this manual, keep it in a safe place
for future reference.



Table of Contents

Chapter 8 ISIS/TWAIN Driver Settings

- 1. Before You Start Using the Scanner 8-2
- 2. ISIS/TWAIN Driver Settings Dialog Box 8-4
 - [Basic] Tab Sheet 8-6
 - [Brightness] Tab Sheet 8-14
 - [Image processing] Tab Sheet 8-16
 - [Others] Tab Sheet 8-18
 - [Imprinter/Addon] Tab Sheet 8-25

Chapter 9 Job Registration Tool Settings

- 1. Before Use 9-2
 - Job Function 9-2
 - Starting the Job Registration Tool 9-2
- 2. Job Registration Tool 9-3
- 3. Settings Dialog Boxes 9-5
 - [New/Editing] Dialog Box 9-5
 - [Admin] Dialog Box 9-8

Chapter 10 Practical Examples

- 1. About Basic Condition Settings 10-2
 - Confirming the Basic Conditions for Scanning ... 10-2
- 2. Practical Examples 10-4
 - Scanning Documents of Unregistered
 - Page Sizes 10-4
 - Specifying the Scanning Area 10-5
 - Configuring Scanner Settings According to the Purpose 10-6
 - Registering Your Settings 10-11

Chapter 8 ISIS/TWAIN Driver Settings

1. Before You Start Using the Scanner.....	8-2
2. ISIS/TWAIN Driver Settings Dialog Box	8-4
[Basic] Tab Sheet.....	8-6
[Brightness] Tab Sheet.....	8-14
[Image processing] Tab Sheet	8-16
[Others] Tab Sheet.....	8-18
[Imprinter/Addon] Tab Sheet	8-25

1. Before You Start Using the Scanner

To use the DR-6050C/7550C/9050C with an ISIS/TWAIN-compliant application program, the DR-6050C/7550C/9050C must first be selected as the scanner to be used. This section describes how to select the scanner using CapturePerfect 3.0 (an ISIS-compatible application program). As the scanner selection procedure depends on the application program being used, refer to your application's user's manual if necessary for instructions on selecting the scanner.

1. Click the [Start] button, then select [All Programs] - [CapturePerfect 3.0] - [CapturePerfect 3.0].

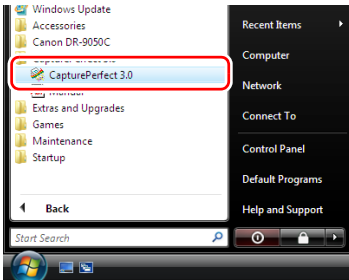

CapturePerfect 3.0 starts.

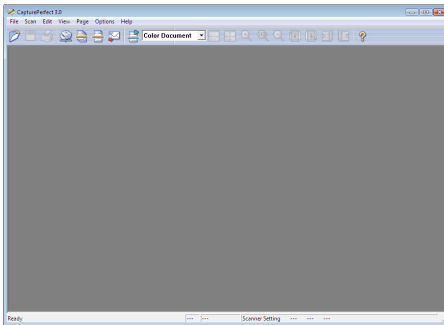

2. Select [Select Scanner] from the [Scan] menu.

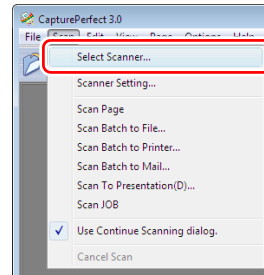

The [Select Scanner] dialog box opens.

3. Select [CANON DR-XXXX], and click [Settings]. (XXXX varies depending on the model you are using)

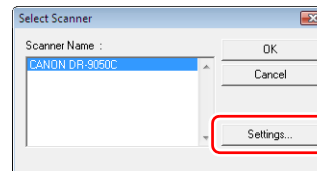

! IMPORTANT

If [CANON DR-XXXX] does not appear, try reinstalling the ISIS/TWAIN driver.

4. Select the default page size and click [OK].

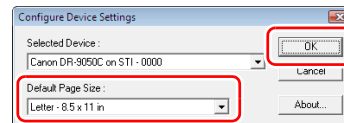

! **IMPORTANT**

- Clicking the [Default] in the ISIS Driver Properties dialog box, the setting is applied here.
- For the TWAIN driver, the default paper size is LTR/A4 and cannot be changed.

5. Click [OK] to finish scanner selection.

2. ISIS/TWAIN Driver Settings Dialog Box

If menus or buttons are selected to configure the scanner settings from an application tool such as CapturePerfect 3.0 or the Job Registration Tool, the following ISIS/TWAIN Driver Settings dialog box is displayed. The ISIS/TWAIN Driver Settings dialog box consists of the standard tab sheets [Basic], [Brightness], [Image processing], [Others], and [Imprinter/Addon]. See the description of each tab sheet for details.



Hint

See [“CapturePerfect 3.0” on p. 3-15](#) for the procedure for executing scans from the scanning application.

ISIS Driver Settings Dialog Box

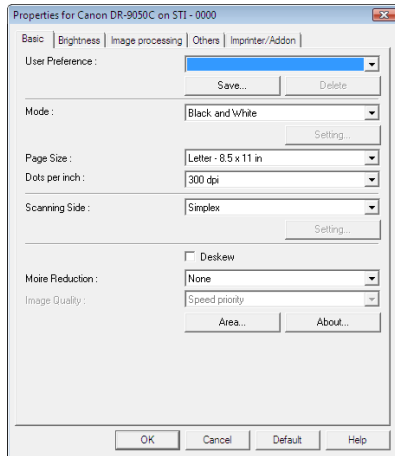

TWAIN Driver Settings Dialog Box

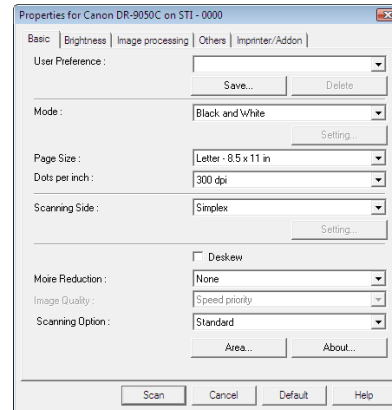

- [Basic] Tab Sheet (See p. 8-6)

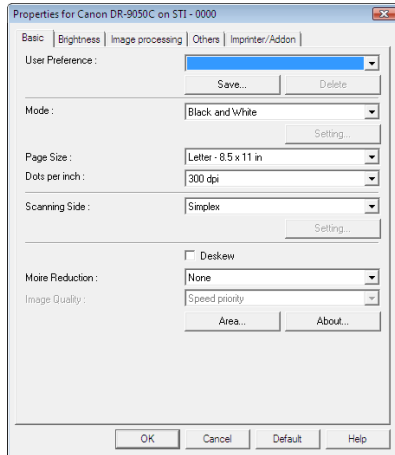

- [Brightness] Tab Sheet (See p. 8-14)

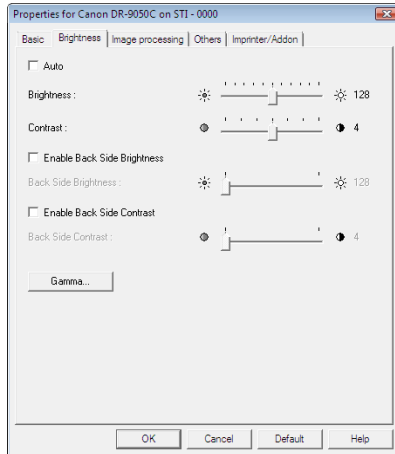

- [Image processing] Tab Sheet (See p. 8-16)

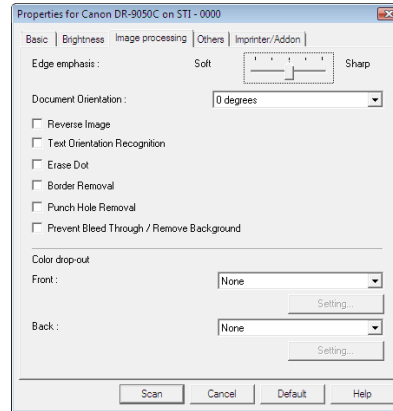

- [Others] Tab Sheet (See p. 8-18)

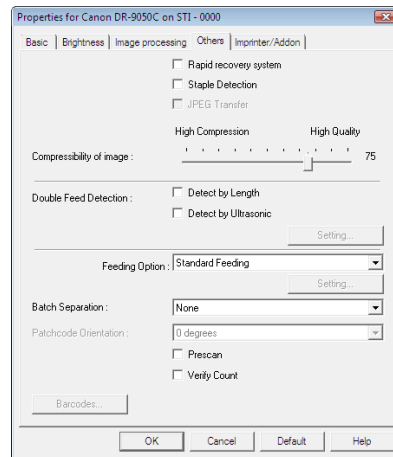

- [\[Imprinter/Addon\] Tab Sheet](#) (See p. 8-25)

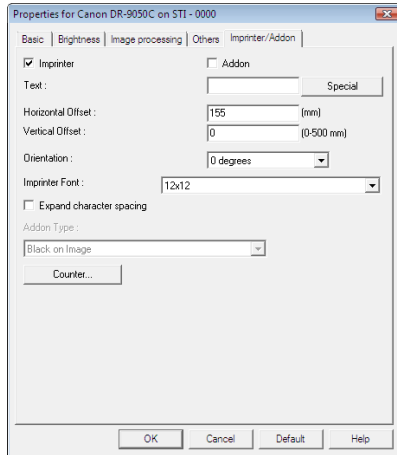

Buttons

[OK] button

Applies the settings and closes the dialog box.



Hint

When you use an application program that scans from the TWAIN Driver Settings dialog box, [Scan] is displayed instead of [OK] to scan with the configured settings. (See “[Scan Area] Dialog Box” on p. 8-12.)

[Cancel] button

Rejects the changes to settings and closes the dialog box.

[Default] button

Returns the settings to their default state.

[Help] button

Displays the Help screen for the open tab sheet and dialog box.

[Basic] Tab Sheet

You can set basic scan conditions on the [Basic] tab sheet. The items that can be set vary depending on the application program you are using. Specify the settings as necessary for the screen that is displayed.

■ [Basic] Tab Sheet Types

The following types of Basic tab sheets can be displayed.

[Basic] Tab (ISIS/TWAIN driver)

This [Basic] tab sheet is displayed for application programs such as CapturePerfect and Job Registration Tool.

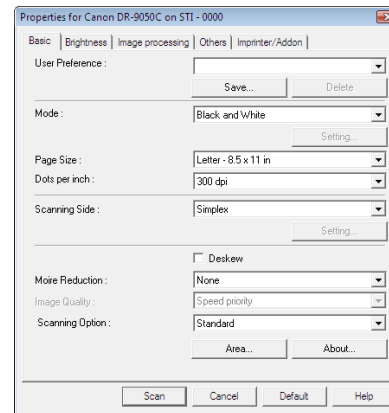

! IMPORTANT

- The [Scanning Option] is a function for setting the TWAIN driver, so it does not appear for the ISIS driver.
- When you use a TWAIN-compatible application program that scans from the settings dialog box, [Scan] is displayed instead of [OK].

[Basic] Tab Advanced Version (ISIS driver only)

This [Basic] tab sheet is displayed when the DR-6050C/7550C/9050C ISIS Driver is utilized from a scanner setting or scanning dialog box belonging to an ISIS-compatible application program.

This tab sheet contains settings for the scanner functions that are not supported in the dialog box belonging to the application program.

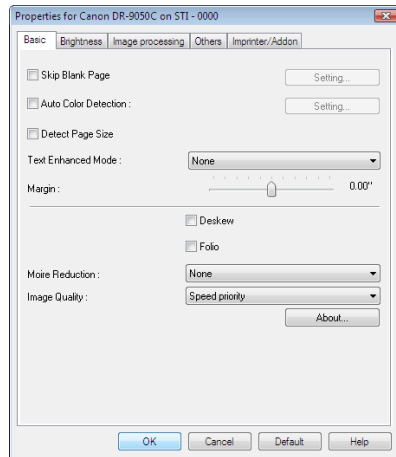

Hint

- For details about [Skip Blank Page], [Auto Color Detection], [Detect Page Size], [Text Enhanced Mode], [Margin], and [Folio], see the descriptions for the following settings.
 - [Skip Blank Page] → [Scanning Side]
 - [Auto Color Detection] → [Mode]
 - [Detect Page Size] → [Page Size]
 - [Text Enhanced Mode] → [Mode]
 - [Margin] → [Scan Area] dialog box
 - [Folio] → [Scanning Side]
- The [Auto Color Detection] setting in the [Basic] tab (Advanced) is enabled only when the color scanning mode is selected in the settings dialog box belonging to the ISIS-compliant application.

■ [Basic] Tab Sheet Settings

You can configure the following settings on the [Basic] tab sheet.

User Preference

Click [Save] to open the [Save User Preference] dialog box.

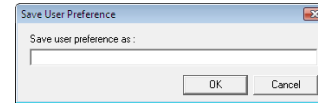

The [Save User Preference] dialog box saves the current settings under an assigned name.

You can select the name of a saved set of user preferences in the list box to load those settings into each tab sheet.

IMPORTANT

Assigned names can consist of up to 32 characters.

Mode

Select the mode for scanned images.

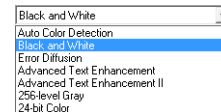

Hint

- Some functionality is limited depending on the mode setting. (See “Mode-Dependent Function Limitations” on p. 8-11 and “[Brightness] Tab Sheet” on p. 8-14.)
- Advanced text enhancement modes are useful if you want to scan documents with a background color or design behind the text as black-and-white images, and remove or process the surrounding background to enhance the text for easy reading.
- Two advanced text enhancement modes are provided to suit different background types. Select the mode that best suits your document. We recommend confirming the image by rescanning the first page.
- When saving an image file in JPEG format, select [256-level Gray] or [24-bit Color].

[Auto Color Detection]

The document is detected as black-and-white or color before the scanned image is saved.

Selecting this mode enables the [Setting] button for opening the [Auto Image Type Detection Settings] dialog box, where you can make settings for auto image type detection. (See “[Auto Image Type Detection Settings] Dialog Box” on p. 8-11.)

IMPORTANT

Depending on the application program, operation may become unstable when [Auto Color Detection] is enabled. In that case, [Auto Color Detection] should be disabled.

[Black and White]

Use this mode to scan text and line drawing documents as black-and-white (binary) images.

[Error Diffusion]

Use this mode to scan documents containing photos as black-and-white (binary) images.

[Advanced Text Enhancement]

Use this mode to scan documents with a dark or non-uniform (pattern) background.

Hint

- If the background is uniform, it is removed where it surrounds the text.
- If the background is non-uniform, such as a pattern, it is processed to enhance text readability.

[Advanced Text Enhancement II]

This mode is displayed when the resolution is 300 dpi or lower, and is good for scanning documents with uniform background colors or light text and backgrounds.

Hint

- The background in tight spaces around text may not be removed.
- Documents with low-contrast text can be made more readable by adjusting Contrast on the [Brightness] tab sheet.

- If the background is non-uniform, such as a pattern, the background remains visible in the image, and text may be difficult to read.

[256-level Gray]

Scans documents, such as photos, as 256-level grayscale images.

[24-bit Color]

Scans documents, such as color photos, as full-color images.

Page Size

Select the page size of the document to be scanned.

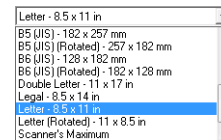

IMPORTANT

- Select [Auto-detection] to scan the following kinds of documents.
 - Documents of a non-standard size
 - Documents containing pages of different sizes
 - When using the Long Document mode (See “[Long Document Mode Setting]” on p. 3-4.)
- When [Auto-detection] is selected, the area settings in the Scan Area dialog box are disabled.
- The [Auto-detection] process may malfunction in the following situations. If this occurs, select a standard size such as [A4] or [Letter], or click the [Area] button to create a custom page size. (See “[Scan Area] Dialog Box” on p. 8-12.)
 - When scanning a page with a dark area at the left or right edge
 - When scanning a glossy or reflective document
 - When the brightness setting is incorrect
 - When the Custom setting is selected in the Gamma Settings dialog box
- Depending on the application program, operation may become unstable when [Auto-detection] is enabled. In that case, [Auto-detection] should be disabled.

Dots per inch

Select the scanning resolution.

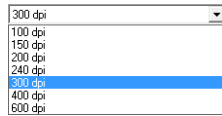

Hint

- Higher resolutions provide clearer images, but produce larger files.
- The [Moire Reduction] setting is enabled when the resolution is set to 300 dpi or lower, and the [Image Quality] setting is enabled when the resolution is set to 400 or 600 dpi.
- The [Advanced Text Enhancement II] mode cannot be used when the resolution is set to 400 or 600 dpi.

Scanning Side

Select which page side(s) to scan.



[Simplex]

Scans the front side (top) of documents.

[Duplex]

Scans both sides of documents.

[Skip blank page]

As each document page is scanned, its scanned image is judged as to whether it is blank, and if so, the image is not saved.

Hint

- When the [Scan Options] on the [Basic] tab sheet is set to [Scan Single Page] for the TWAIN driver, the scanning side is set to [Simplex] and cannot be changed. (See “[Scan Options] (TWAIN driver only)” on p. 8-10.)



- Selecting [Skip blank page] enables the [Setting] button, which opens the [BlankSkip Setting] dialog box.

- Adjust the [Content density] setting in the [BlankSkip Setting] dialog box if you specify [Skip blank page], but blank pages are not skipped, or if non-blank pages are skipped.

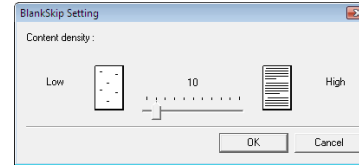

- Adjust the content density according to the document content.
 - When blank pages are not skipped, increase the content density.
 - When non-blank pages are skipped, reduce the content density.
- If the application program provides its own simplex/duplex scanning side setting, select Simplex for this setting.

[Folio]

Documents that are normally folded in half are scanned on both sides and then composed into one image. (See “Folio Scan” on p. 4-6.)

Hint

When [Folio] is not displayed, the batch separation setting on the [Others] tab sheet is set to [Patchcode] (Optional). (See “Batch Separation” on p. 8-20.)

[Deskew] Check Box

The Deskew function detects slanted document pages and straightens the scanned images.

IMPORTANT

The Deskew function does not work properly in the following situations. Disable the Deskew function in these cases.

- When scanning a page with a dark area near the edge of the page
- When scanning a glossy or reflective document
- When the brightness setting is incorrect
- When the Custom setting is selected in the Gamma Settings dialog box

Moire Reduction

This setting is enabled when the resolution is set to 300 dpi or lower. Use Moire reduction if the Moire (a shimmering, wavy pattern) effect appear in scanned images.

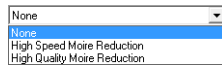

Hint

[High-Speed Moire Reduction] is displayed when the resolution is set to 240 dpi or lower.

[None]

No moire processing is performed.

[High-Speed Moire Reduction]

This mode gives priority to scanning speed, and generates images with the specified resolution from images scanned at 300 dpi.

[High-Quality Moire Reduction]

This mode gives priority to image quality, and generates images with the specified resolution from images scanned at 600 dpi.



IMPORTANT

- Selecting [High-Quality Moire Reduction] produces high-quality images, but the scanning speed is slower.
- If [High-Quality Moire Reduction] is selected, [Auto-detection] is selected for the document size, the color mode is set to [24-bit Color], and the scanning side is [Duplex], the scanner may run out of memory and be unable to scan the entire document. If this occurs, enable [Speed Priority] and scan images of lower quality, or set the scanning side to [Simplex].

Image Quality

When the scanning resolution is set to 400 or 600 dpi, you can enable this setting and select either [Speed Priority] or [Image Quality Priority].

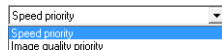

[Speed priority]

This mode gives priority to scanning speed, and generates images of 400 or 600 dpi from images scanned at 300 dpi.

[Image quality priority]

This mode gives priority to image quality, and scans at 600 dpi.

When the resolution is set to 400 dpi, images of 400 dpi are generated from images scanned at 600 dpi.

! IMPORTANT

- Selecting [Speed priority] increases the scanning speed, but the image quality is reduced slightly.
- If [Image quality priority] is selected, [Auto-detection] is selected for the document size, the color mode is set to [24-bit Color], and the scanning side is [Duplex], the scanner may run out of memory and unable to scan the entire document. If this occurs, enable [Speed priority] and scan images of lower quality, or set the scanning side to [Simplex].

[Scan Options] (TWAIN driver only)

Specify the operation when scanning continuously with a TWAIN-compatible application program.

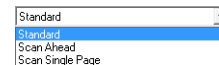

[Standard]

Outputs each scanned page before scanning the next page.

[Scan Ahead]

Scan pages continuously. Scanning speed is faster than [Standard].

[Scan Single Page]

The [Scanning Side] setting on the [Basic] tab sheet is changed to [Simplex], and one page is scanned.

[Area] button

Open the [Scan Area] dialog box to specify the area to scan. (See “[Scan Area] Dialog Box” on p. 8-12.)

! IMPORTANT

The [Area] button is not displayed if the application program provides its own function to specify the scan area.

■ Mode-Dependent Function Limitations

The following tab sheet functions are partially disabled according to the selected mode. For details on the [Brightness] tab sheet settings, see “[Brightness] Tab Sheet” on p. 8-14.

		Settings Tab Sheet									
		Basic		Image processing					Others		
Scanning Modes	Auto Color Detection	✓	✓	✓	✓	✓	✓	-	✓	-	-
	Black and White	✓	✓	✓	✓	✓	✓	✓	-	✓	✓
	Error Diffusion	✓	✓	✓	-	✓	✓	✓	-	✓	✓
	Advanced Text Enhancement	✓	✓	✓	✓	✓	-	✓	-	✓	✓
	Advanced Text Enhancement II	✓	✓	-	✓	✓	-	✓	-	✓	✓
	256-level Gray	✓	✓	✓	-	✓	✓	✓	✓	✓	✓
	24-bit Color	✓	✓	✓	-	✓	✓	-	✓	✓	✓
	Deskew										
Moire Reduction											
Edge emphasis											
Erase Dot											
Border Removal											
Prevent Bleed Through / Remove Background											
Color drop-out											
JPEG Transfer											
Batch Separation (ISIS driver)											
Prescan											

✓ : available for setting, - : not available for setting, or auto

■ [Auto Image Type Detection Settings] Dialog Box

This dialog box appears when you select [Auto Color Detection], and enables you to make settings for detecting whether scanned images are in color or black-and-white, and select the mode to use when an image is detected as black-and-white.

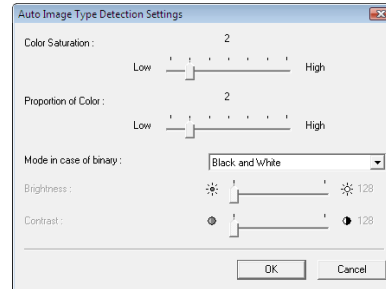

Color Saturation/Proportion of Color

These settings are for judging whether a document is in color.

Depth of color in documents is detected by [Color Saturation], and [Proportion of Color] is used to judge a color document.

! IMPORTANT

- Changing these settings is not normally necessary. Change them only if you want a document of light colors to be judged to be a black-and-white document.
- Select [24-bit Color] if color documents are judged to be black-and-white documents with the default settings.

[Mode in case of binary]

Select the scanning mode when a page is judged to be black-and-white.

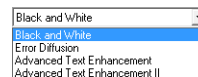

Brightness and Contrast

Adjust the brightness and contrast when [Advanced Text Enhancement] or [Advanced Text Enhancement II] is selected for [Mode in case of binary]. For other modes, the brightness and contrast are set on the [Brightness] tab sheet.

■ [Scan Area] Dialog Box

In this dialog box you can define the area of the document page to scan on a selected page size, and register non-standard document page sizes.

The Scan Area dialog box is different for ISIS and TWAIN drivers: for the TWAIN driver, one of two dialog box types is displayed, depending on the application program used.

Scan Area Dialog Box (ISIS Driver)

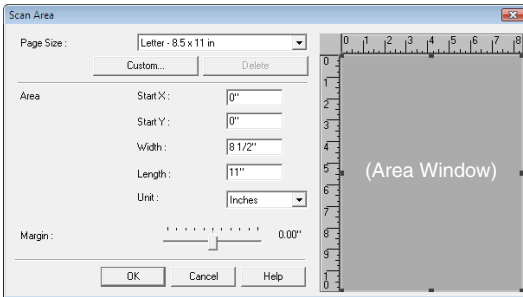

Scan Area Dialog Box (TWAIN Driver)

This dialog box appears with application programs that display the [Scan] button in the Properties dialog box.

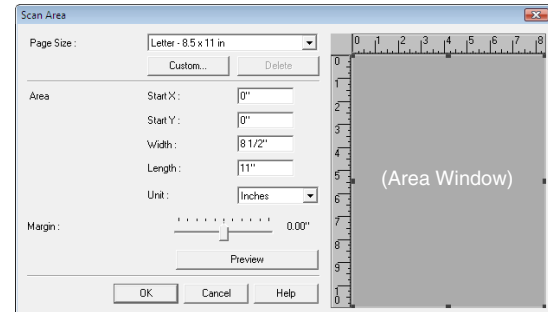

The Area panel and [Preview] button are not displayed when using application programs, like the Job Registration Tool, that display the [OK] button in the Properties dialog box.

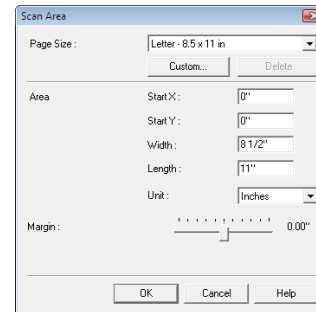

Page Size

This setting is linked to the [Page Size] setting, for selecting the size of the document pages to scan.

Hint

Clicking the [Custom] button opens the [Custom Page Size] dialog box, where non-standard page sizes can be registered as custom page sizes.

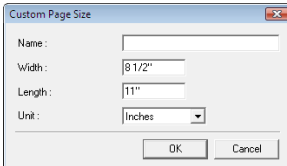

Area

Select the area to be scanned.

Hint

- The region settings are ignored under the following settings.
 - The paper size is [Auto-detection]
 - [Text Orientation Recognition] is enabled in the [Image Processing] tab
- If [Deskew] is enabled in the [Basic] tab, the specified region is scanned offset.

Area Window

The size indicated for the Area panel corresponds to the page size setting, and the area within the panel indicates the current scanning area.

Hint

- The scanning area can be adjusted by dragging the handles (■) bordering the Area panel with your mouse.
- With CapturePerfect, the last scanned image appears in the Area panel.

Margin

This control adjusts the top, bottom, left, and right margins around the scanning area so that you can expand the scanning area to include the edges of a document, or reduce it to avoid black frames around scanned images.

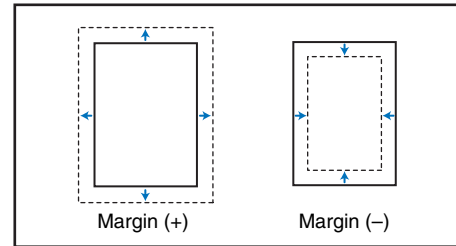

Hint

- If the edges of documents are missing from scanned images, move the slider to the right to expand the scanning area.
- To eliminate the black frame around scanned images, reduce the scanning area by moving the slider to the left.
- The measurement units for margins are determined by the [Unit] setting. However, changing the margin [Unit] setting is not possible on the advanced version of the [Basic] tab sheet (p. 8-7).

[Preview] Button (TWAIN driver only)

Load the document and then click the [Preview] button to scan one document page and display its preview image in the Area panel.

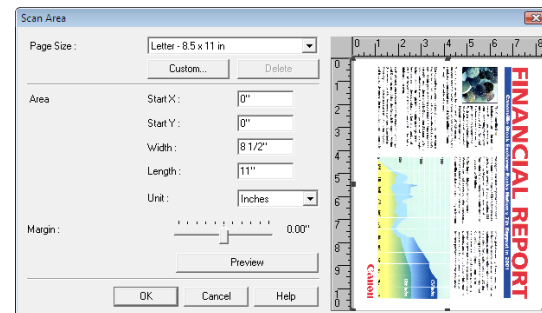

[Brightness] Tab Sheet

On the [Brightness] tab sheet you can adjust brightness and contrast for scanning, and access gamma settings. The availability of brightness and contrast settings depends on the mode setting of the [Basic] tab sheet.

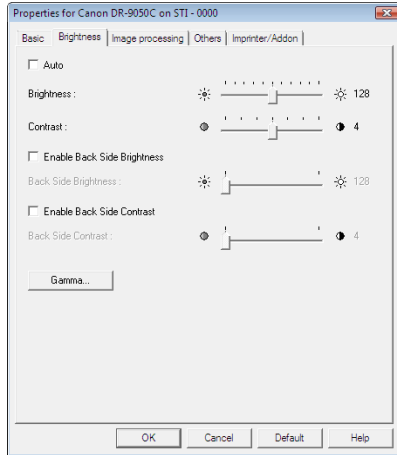

Hint

If all of the settings on the [Brightness] tab sheet are disabled, the gamma setting is set to Custom. (See "[Gamma Settings] Dialog Box" on p. 8-15.)

The availability of brightness and contrast settings are as follows, according to the mode setting on the [Basic] tab sheet.

		Setting				
		Auto	Brightness	Contrast	Enable Back Side Brightness	Enable Back Side Contrast
Scanning Modes	Auto Color Detection	–	✓	✓	✓	✓
	Black and White	✓	✓	✓	✓	✓
	Error Diffusion	–	✓	✓	✓	✓
	Advanced Text Enhancement	–	✓	–	–	–
	Advanced Text Enhancement II	–	✓	✓	–	–
	256-level Gray	–	✓	✓	✓	✓
	24-bit Color	–	✓	✓	✓	✓

✓ : available for setting, – : not available for setting, or auto

■ [Brightness] Tab Sheet Settings

You can configure the following settings on the [Brightness] tab sheet.

[Auto] Check Box

This is enabled when the scanning mode is [Black and White]. The brightness and contrast are adjusted according to the document.

Brightness

Adjusts the brightness of images to be scanned.

Hint

- If images are too dark or if text on the back of a sheet bleeds through, you can drag the slider to the right to increase the setting.
- If images are too light, drag the slider to the left to decrease the setting.

- When the [Auto] check box is selected, the slider automatically selects a brightness level to be used for automatic adjustment.

Contrast

Adjusts the contrast of images to be scanned.

[Enable Back Side Brightness] Check Box

If the brightness of the front and back of the document pages is different, select this check box to adjust only the brightness of the back side.

[Enable Back Side Contrast] Check Box

If the contrast of the front and back of the document pages is different, select this check box to adjust only the contrast of the back side.

■ [Gamma Settings] Dialog Box

Use the [Gamma Settings] dialog box to adjust the gamma correction value.

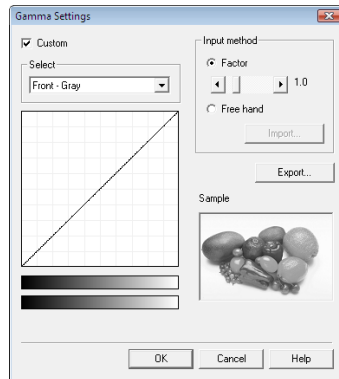

[Custom] Check Box

Select this check box to set custom gamma correction.

Select

Select the side and color for custom setting.

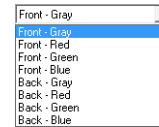

Hint

The color bar and color of the sample image are changed to show the specified color.

Input method

Select the setting method for gamma correction.

[Factor]

Move the slider to the left or right to adjust the gamma correction factor between 0.2 and 5.0.

Hint

- The gamma correction value, Gamma Curve Graph, and sample image color are interlinked. When you adjust one of these items, the others are also adjusted automatically.
- Clicking at a point in the Gamma Curve Graph with your mouse changes the gamma curve and color of the sample image to match that point.
- You can also move the gamma curve by dragging it with the mouse.

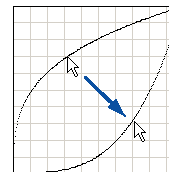

[Free hand]

The output value for a particular input value in the gamma table can be specified with the mouse.

Hint

- Click any point in the Gamma Curve Graph to set that point as an output value.
- Drag the mouse on the Gamma Curve Graph to set the output value according to the mouse movement.

[Import] button

Clicking this button loads the gamma table data (*.pxg) that was previously stored with the [Export] button.

Hint

Imported gamma data is reflected in the Gamma Curve Graph.

[Export] button

Clicking this button exports the custom gamma curve settings as a gamma table file (*.pxg).

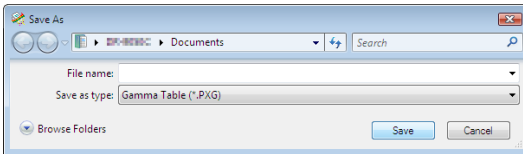
**[Image processing] Tab Sheet**

The [Image processing] tab sheet provides settings affecting the processing of scanned images. Some settings may be disabled, depending on the mode settings on the [Basic] tab sheet. For details, see “[Mode-Dependent Function Limitations](#)” on p. 8-11.

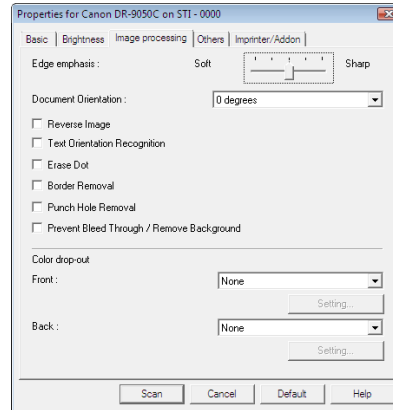
**■ [Image processing] Tab Sheet Settings**

You can configure the following settings on the [Image processing] tab sheet.

Edge emphasis

Adjusts the image contours. Move the slider toward Soft to soften the image contours, or toward Sharp to sharpen the image contours.









Document Orientation

Specify a rotation angle to correct the orientation of images.



Hint

Scanned images are rotated as follows, according to the orientation of loaded documents and the selected angle.

Feeder Document: Face Up	 ABC	 ABC	 ABC	 ABC
Document Orientation (Clockwise)	0 degrees	90 degrees	180 degrees	270 degrees
Output Image				

[Reverse Image] Check Box (TWAIN driver only)









Select this check box to output images scanned in black-and-white (binary) with the black-and-white shades reversed.

IMPORTANT

This function is not available when the color mode is set to [256-level Gray] or [24-bit Color].

[Text Orientation Recognition] Check Box

Select this check box to detect text orientation in scanned images, and rotate the images in 90° increments as needed to normalize orientation.

Text Orientation	 ABC	 ABC	 ABC	 ABC
Output Image				

IMPORTANT

- When [Text Orientation Recognition] is selected, the [Document Orientation] and area settings set in the Scan Area dialog box are disabled.
- Some application programs do not support [Text Orientation Recognition]. Please disable [Text Orientation Recognition] if your application program behaves abnormally when this setting is enabled.

[Erase Dot] Check Box

Select this check box to remove isolated pixels (up to 3x3 dots) from a white background.

[Border Removal] Check Box

Select this check box to remove black areas created around images during scanning.

[Punch Hole Removal] Check Box

Select this check box to remove black circles created during scanning of documents with punch holes for storage in a binder.

IMPORTANT

If punch holes are located within text or graphics in the document, they may be misidentified as graphics, and may not be removed.

[Prevent Bleed-Through / Remove Background] Check Box

Select this check box to prevent bleed-through when scanning thin document pages and those with dark content on the back side, or to remove the background from document images.

Color drop-out

These selections are enabled for scanning modes other than 24-bit Color, so that you can select a primary color (red, green, blue) or gray to be ignored (dropped out) or enhanced.

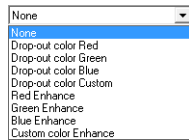

The [Setting] buttons are enabled when [Drop-out color Custom] or [Custom Color Enhance] is selected, so that you can specify a color range in the [Color Settings] dialog box for drop-out or enhancement.

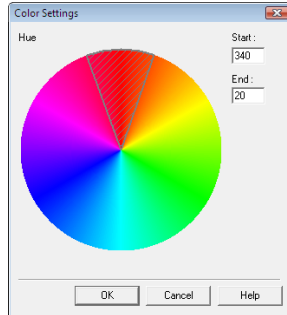

Hint

- The color range within the shaded (cross-hatched) area is dropped out or enhanced.
- You can move the shaded area by dragging with the mouse.
- You can change the specified color range by dragging the edges of the shaded area.
- Because your operating environment affects the colors you specify on screen, they may not match those actually dropped out or enhanced: that is, the colors you specify may not match those processed.

[Others] Tab Sheet

The settings on the [Others] tab sheet are different for the ISIS and TWAIN drivers. Also, some settings may be disabled, depending on the mode settings on the [Basic] tab sheet. For details, see “[Mode-Dependent Function Limitations](#)” on p. 8-11.

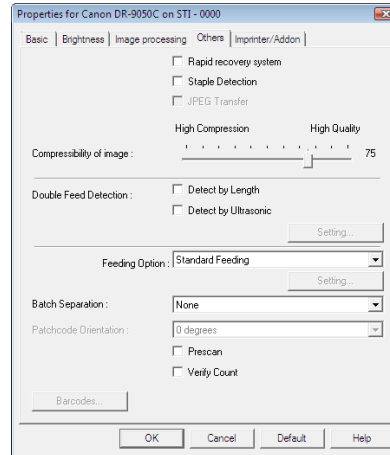

Hint

[Batch Separation] and [Patchcode Orientation] are functions for setting the ISIS driver, so they are not displayed for the TWAIN driver.

■ [Others] Tab Sheet Settings

You can configure the following settings on the [Others] tab sheet.

[Rapid Recovery System] Check Box

If a paper jam causes paper transport to stop while scanning, scanning stops without sending an error notification to the application program. After fixing the cause of the stoppage, you can continue scanning.

[Staple Detection] Check Box

Select this check box to stop feeding when the sensor detects a folded corner on a document, which occurs when an attempt is made to feed stapled documents. (See “Staple Detection” on p. 4-6.)

[JPEG Transfer] Check Box

When this check box is selected, scanned image data is always compressed to JPEG format within the scanner for output to the computer.

 Hint

- Scanned image data is output from the scanner as an uncompressed or JPEG transfer, depending on instructions from the ISIS/TWAIN driver or application program.
 - With uncompressed transfer, scanned image data is output without being compressed. Therefore, if the image data is large, transfer of the data from the scanner to the computer may take a long time.
 - JPEG transfer is useful for color and grayscale images, as scanned image data is JPEG-compressed within the scanner before it is output. This reduces the size of the image data for output, so transfer time from the scanner to the computer is shortened.
- When JPEG Transfer is selected, image data from the scanner is always output as JPEG-compressed data.
 - When the uncompressed saving format is selected in the application program, JPEG-compressed image data is reconverted to uncompressed data before it is transferred to the application. Image quality deteriorates as a result.
 - This check box setting is ignored if the application program requests a JPEG transfer.
 - Application program requests depend on the specifications of the particular program.

Image Compression Ratio

Adjusts the compression ratio of the scanned image data. Moving the slider towards [High Quality] reduces the compression ratio and increases the image quality. Moving towards [High Compression] increases the compression ratio. Although this reduces the file size, the image quality is also reduced.

Double Feed Detection

This function stops document transport when double feeding of document pages is detected, and enables you to select the detection method to suit the type of documents to be scanned. (See “Double-Feed Detection” on p. 4-5.)

[Detect by Length]

This method of double feed detection is useful for batch scanning of same-size documents. The length of the first document page fed is measured as a standard, and if a subsequent document is detected to be 1.38" (35 mm) longer (or shorter) than the standard, a double feed is judged to have occurred, and document transport is stopped.

[Detect by Ultrasonic]

This method of double feed detection is useful for batch scanning of different-size documents. When the ultrasonic sensor detects overlapping documents and spacing between documents, a double feed is judged to have occurred, and document transport is stopped.

 Hint

Both detection methods can be used together.

[Setting] Button

This button is enabled when [Detect by Ultrasonic] is selected, and displays the [Detect Double Feed Setting] dialog box.

In the [Detect Double Feed Setting] dialog box, you can select the sensor position for detection and set a non-detection area so that the area where a stamp or label is affixed to the document page is not detected as a double feed.

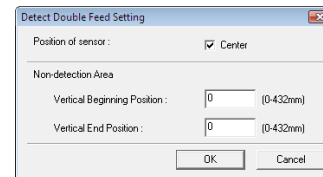

! IMPORTANT

If the documents overlap by less than 1.97" (50 mm), or if the documents cling (such as from static electricity), ultrasonic detection of double feeds may not work correctly.

Feeding Option

You can select the feeding method for document scanning.

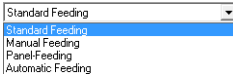
**[Standard Feeding]**

Load a document and then start scanning with an application program. Scanning stops when the loaded document has been scanned.

[Manual Feeding] (Separation Off)

This is linked to the [Separation Off] key on the control panel. When [Manual Feeding] is selected, the [Separation Off] key is lit and the Document Feed Tray is raised up. Start scanning with an application program and feed documents manually one at a time. The scanner detects a document and then scans it. Press the stop key to stop scanning.

💡 Hint

If you press the [Separation Off] key on the control panel, the feeding option changes to [Manual Feeding].

[Panel-Feeding]

Start scanning with an application program, load a document, and then press the start key to start the scan operation.

The scanner enters a waiting state when the document has been scanned, and then continues scanning when you load the next document and press the start key. When all of the documents have been scanned, press the stop key to stop scanning.

💡 Hint

When using the panel feeding mode to scan documents with different-size pages, you can adjust the document guide position after loading a document.

[Automatic Feeding]

Execute scanning with an application. The scanner starts scanning when it detects a document loaded in the Document Feed Tray.

The scanner enters a waiting state when the document has been scanned, and then continues scanning when it detects the next document. When all of the documents have been scanned, press the stop key to stop scanning.

[Setting] Button

This button is enabled when [Automatic Feeding] is selected, and allows you to set the delay time from when a loaded document is detected until scanning starts.

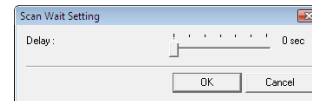
**Batch Separation**

Items available for selection depend on the Feeding Option setting: select batch separation timing (for when to start scanning) according to the batch separation capabilities provided by the application program.

[Standard Feeding] feeding option, batch separation is not available

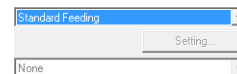
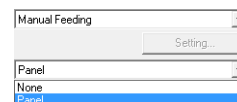
**[Manual Feeding] Feeding Option**

[Panel-Feeding] or [Automatic Feeding] Feeding Option

[Auto]

Each batch of documents is saved with different file names.

[Panel]

A batch is separated when you press the [New File] key on the control panel to start or continue scanning.

Batch Separation (when a patchcode decoder is installed)

When the optional patchcode decoder is installed, batch separation by patchcode is enabled for all feeding option settings.

[Standard Feeding] Feeding Option

[Manual Feeding] Feeding Option

[Panel-Feeding] or [Automatic Feeding] Feeding Option

[Patchcode]

Batches are separated whenever a patchcode sheet is detected between documents. (See “Using Patchcode Sheets (Option)” on p. 3-20.)

! IMPORTANT

- When [Patchcode] is selected, the [Folio] Scanning Side setting on the [Basic] tab sheet is not available.
- When Multi-Stream is enabled in the application program, [Patchcode] is not displayed.

Patchcode Orientation (ISIS driver only)

This function is enabled when the optional patchcode decoder is installed and batch separation is set to [Patchcode]. Set the orientation to match that of the patchcode of the patchcode sheet.

💡 Hint

Settings for various patchcode types and orientations on document pages are as follows.

Patch T (File A)				
Patch II (File B)				
Patchcode Orientation	0 degrees	90 degrees	180 degrees	270 degrees

[Prescan] Check Box

When this check box is selected, the first document page is prescanned and displayed in the Prescan panel when scanning is first started. Continue scanning after you confirm or adjust brightness and contrast of the scanned image in the Prescan window.

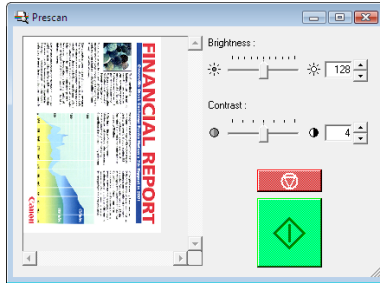
**[Verify Count] Check Box**

When this check box is selected, the count from the scanner's count-only mode or an optionally set count is used as the reference for scanning, and a message is displayed when the set count differs from the number of pages scanned. (See "Count-Only Mode" on p. 4-4.)

[Barcodes] button

This button is enabled when the optional barcode module is installed, and opens the [Barcode] dialog box for configuring settings for detecting barcodes in documents.

[Barcode] Dialog Box Settings

The [Barcode] dialog box is displayed when you click the [Barcode] button, and allows you to configure settings related to detecting barcodes.

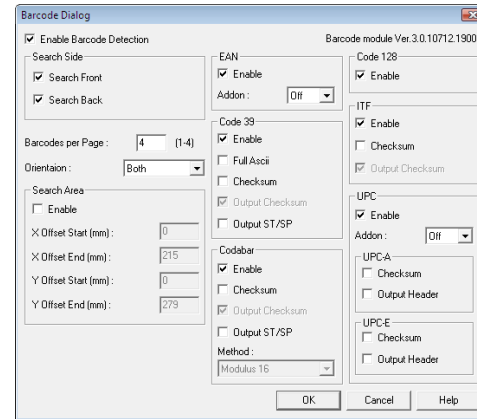
**! IMPORTANT**

- For details on barcode specifications, see "Barcode Specifications" on p. 7-5.
- If your application supports barcodes, barcode data that is detected can be read. When using CapturePerfect 3.0, barcode data is saved to the specified log file.

[Enable Barcode Detection] Check Box

Select this check box to detect barcodes in scanned documents.

💡 Hint

- Barcode detection only applies to barcodes within the scanning area.
- To detect only certain barcodes when scanning documents with multiple barcodes, you can set the detection area with the barcode area setting.

[Search Side]

Select the side(s) of the document on which to detect barcodes.

[Search Front]

Detect barcodes on the front side of documents.

[Search Back]

Detect barcodes on the back side of documents.

[Barcodes per Page]

Sets the number of barcodes (1 to 4) to detect per page.

[Orientation]

Set the orientation of the barcodes to detect.

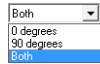
**[Hint]**

Barcodes that scan perpendicular to the feeding direction have 0-degree orientation, and those that scan parallel to the feeding direction have 90-degree orientation, and detection is possible regardless of which end is the starting point.

**[Search Area]****[Enable] check box**

Select this check box to limit barcode detection to within a specified area of the document, and then enter the start positions and end positions for the horizontal direction and vertical direction.

[Hint]

- When specifying an area on the front side of documents, the x-offset is the distance from the left side of the feeder inlet (viewed from the feeding direction).
- When specifying an area on the back side of documents, the x-offset is the distance from the right side of the feeder inlet (viewed from the feeding direction).
- The y-offset is the distance from the top of the page.

EAN

Detect EAN barcodes.

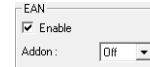
**[Enable]**

Detect and read EAN barcodes.

[Addon]

Set how to handle addon codes included in barcodes.



Off: Ignore addon codes.

On: Read addon codes.

Auto: Detect and read addon codes automatically.

Code 39

Detect Code 39 barcodes.

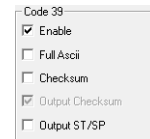
**[Enable]**

Detect and read Code 39 barcodes.

[Full Ascii]

Read barcodes in Full ASCII Code.

[Checksum]

Read the checksum included in barcodes.

[Output Checksum]

This check box is enabled when [Checksum] is selected, and outputs the read checksum.

[Output ST/SP]

Select this check box to output Start and Stop codes.

Codabar

Detect Codabar barcodes.

Codabar

Enable

Checksum

Output Checksum

Output ST/SP

Method :
Modulus 16

[Enable]

Detect and read Codabar barcodes.

[Checksum]

Read the checksum included in barcodes.

[Output Checksum]

This check box is enabled when [Checksum] is selected, and outputs the read checksum.

[Output ST/SP]

Output Start and Stop codes included in barcodes.

[Method]

Select the checksum calculation method.

Code 128

Detect Code 128 barcodes.

Code 128

Enable

[Enable]

Detect and read Code 128 barcodes.

ITF

Detect ITF barcodes (including industrial 2 of 5).

ITF

Enable

Checksum

Output Checksum

[Enable]

Detect and read ITF barcodes.

[Checksum]

Read the checksum included in barcodes.

[Output Checksum]

This check box is enabled when [Checksum] is selected, and outputs the read checksum.

UPC

Detect UPC-A/UPC-E barcodes.

UPC

Enable

Addon : Off

UPC-A

Checksum

Output Header

UPC-E

Checksum

Output Header

[Enable]

Detect and read UPC-A/UPC-E barcodes.

[Addon]

Set how to handle addon codes included in barcodes.

Off

On

Auto

Off: Ignore addon codes.

On: Read addon codes.

Auto: Detect and read addon codes automatically.

[Checksum]

Read the checksum included in barcodes.

[Output Header]

Select this check box to output header codes.



Hint

- To detect barcodes with and without add-on codes at the same time, select [Auto] for the add-on setting before scanning.
- When the barcode type is unknown, enable detection of all types (Auto Detect), and deselect the Checksum boxes before scanning.

[Imprinter/Addon] Tab Sheet

The [Imprinter/Addon] tab sheet allows you to imprint/add any character string or counter on scanned documents.

The [Imprinter] check box is enabled only if the optional imprinter unit is installed.

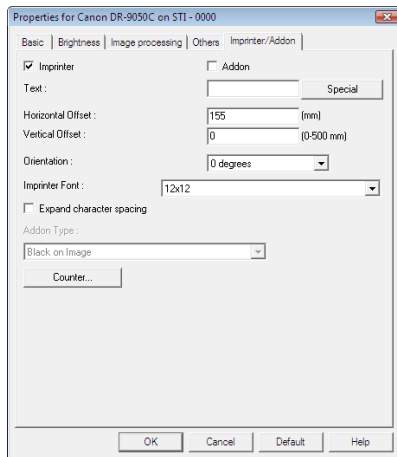

■ [Imprinter/Addon] Tab Sheet Settings

You can configure the following settings on the [Imprinter/Addon] tab sheet.

Check Boxes

[Imprinter] Check Box

Configure settings for imprinting any character string or counter on scanned documents.



IMPORTANT

Confirm that an ink cartridge is installed in the scanner before you use the imprinter function. "Check Imprinter" is displayed on the scanner LCD if scanning is performed without the ink cartridge.

[Addon] Check Box

Configure settings for adding any character string or counter on scanned images.

Text

Enter any character string to be imprinted or added.



Hint

The following characters can be entered.

- Numerals: 0 to 9
- Alphabetic characters: A to Z and a to z
- Symbols: !"#\$%&()' * + - . , / : ; < > = ? @ [] { } ~ ` \

Enter special text such as counters, dates and arrows from the list that appears by clicking the [Special] button.

The selected abbreviation is inserted into the text string.

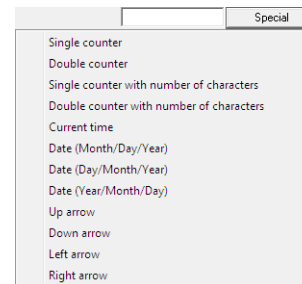

[Single counter] abbreviation: <C>

Print/add one 9-digit counter.

[Double counter] abbreviation: <CC>

Print/add two 9-digit counters.

[Single counter with number of characters]

abbreviation: <Cx>

A dialog box appears in which to specify the number of characters of the single counter. A counter of the specified number of characters will be imprinted or added on scanned images.

[Double counter with number of characters]

abbreviation: <CxCx>

A dialog box appears in which to specify the number of characters of the double counter. A counter of the specified number of characters will be imprinted or added on scanned images.

[Current time] abbreviation: <TIME>

Imprint/add the time of scanning using 8 digits in 24-hour format.

[Date (Month/Day/Year)] abbreviation: <MDY>

Imprint/add the date of scanning using 10 digits in Month/Day/Year format.

[Date (Day/Month/Year)] abbreviation: <DMY>

Imprint/add the date of scanning using 10 digits in Day/Month/Year format.

[Date (Year/Month/Day)] abbreviation: <YMD>

Imprint/add the date of scanning using 10 digits in Year/Month/Day/format.

[Up arrow] abbreviation: <U>

Imprint/add an up arrow (↑).

[Down arrow] abbreviation: <D>

Imprint/add a down arrow (↓).

[Left arrow] abbreviation: <L>

Imprint/add a left arrow (←).

[Right arrow] abbreviation: <R>

Imprint/add a right arrow (→).

! IMPORTANT

- Special text can only be entered for one type of counter. If you enter two types of counter and click [OK], an error message is displayed.

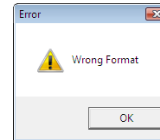

- A maximum of 32 characters can be imprinted or added, but the number of characters you can enter may be limited by the font size.

If the number of characters entered exceeds the limit, an error message is displayed when you click [OK].

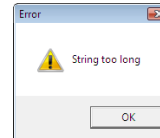

Horizontal Offset

Enter the distance from the left of the feeder inlet.

Vertical Offset

Enter the distance from the top edge of the page. (0" to 19.69") (0 to 500 mm)

Hint

The input range changes if Long Document Mode is enabled. The input range is (0" to 39.37") (0 to 1000 mm) when Long Document Mode is set to [ON1], and (0" to 118.11") (0 to 3000 mm) when it is set to [ON2].

Orientation

Specify the orientation of characters to be imprinted or added.



Hint

Text orientation relative to the feeding direction is as follows.

Orientation	0 degrees	90 degrees	180 degrees	270 degrees
Print	↑ A B C...	↑ ... C B A	↑ A B C...	↑ ... C B A

Imprinter Font

Specify the font size of characters to be imprinted or added.

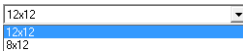

[Expand character spacing]

Select this check box to expand the spacing between printed or added characters.

Addon Type

Specify the method in which text is added on to the image.



[Black on White]

Add black text on to a white background.

[White on Black]

Add white text on to a black background.

[Black on Image]

Add black text on to an image.

[Counter] button

Open the [Counter] dialog box, and configure counter settings.

■ [Counter] Dialog Box

Make settings for add-on counters.

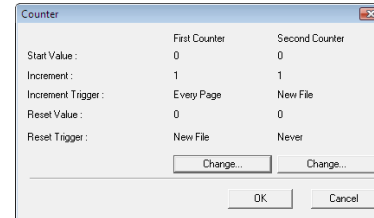

First Counter

This is the current setting for the single counter, or for the first counter if double counters are selected.



Hint

The setting can be changed in the [Counter] dialog box.

Second Counter

This is the current setting for the single counter, or for the second counter if double counters are selected.



Hint

The setting can be changed in the [Counter] dialog box.

■ [First Counter] and [Second Counter] Dialog Boxes

Make settings for add-on counters.

[Start Value]

Enter the start value for the counter.

[Increment]

Enter the increment value for the counter. The counter increases by the value entered here.

[Increment Trigger]

Specifies the type of event that triggers a counter increment.

[New File] (ISIS driver only)

The counter increases when a batch separation occurs according to the Batch Separation settings on the [Others] tab sheet. (See “Batch Separation” on p. 8-20.)

[Every Page]

Increments once per page.

[None]

No counting up.

[Reset Value]

Select the initial value when the counter is reset.

[Reset Trigger]

Select the trigger for resetting the counter.

[New File] (ISIS driver only)

The counter is reset when a batch separation occurs according to the Batch Separation settings on the [Others] tab sheet. (See “Batch Separation” on p. 8-20.)

[Every Page]

Resets the counter once per page.

[None]

No counter reset occurs.

Chapter 9 Job Registration Tool Settings

1. Before Use.....	9-2
Job Function.....	9-2
Starting the Job Registration Tool.....	9-2
2. Job Registration Tool.....	9-3
3. Settings Dialog Boxes.....	9-5
[New/Editing] Dialog Box.....	9-5
[Admin] Dialog Box.....	9-8

1. Before Use

The Job Registration Tool is an application for registering jobs that can be executed from the [Job] key on the control panel. This chapter describes the settings for the Job Registration Tool. For details on the Job Function, see [“About the Job Function”](#) on p. 3-14.

Job Function

The job function is for using the [Job] key on the control panel to select and execute jobs registered by Job Registration Tool, and allows you to execute scanning without using a scanning application.

Hint

- Job registration stores scanning condition settings, image file format selection, save destination and image data processing settings for each job to be used with the Job Function.
- Up to 99 jobs can be registered with the Job Registration Tool.

Starting the Job Registration Tool

Follow the procedure below to start the Job Registration Tool.

1. Click the [Start] button, and then click [All Programs] - [Canon DR-XXXX] - [Job Registration Tool]. (XXXX varies depending on the model you are using)

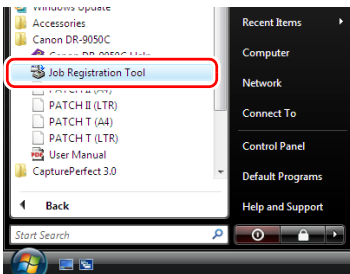

The Job Registration Tool starts.

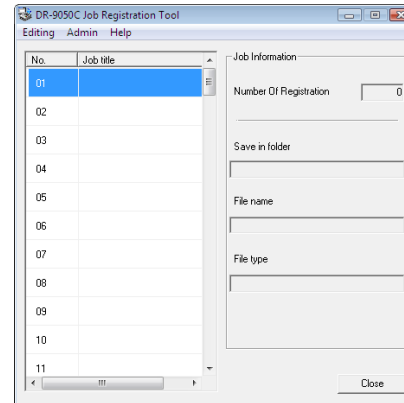

2. Job Registration Tool

The Job Registration Tool consists of the main window below and the [New/Editing] and [Admin] dialog boxes. For details on the dialog boxes, see the description of each dialog box.

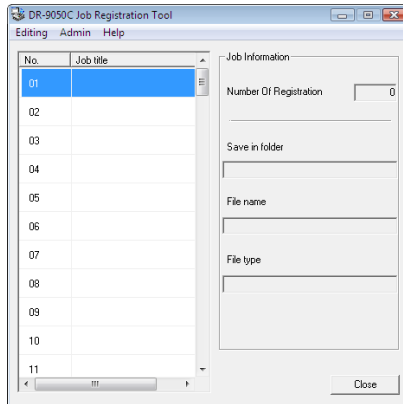

Menu Bar

[Editing] Menu

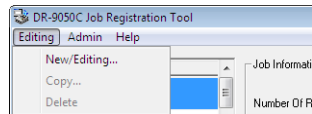

Select a job from the job list, and register a new job or edit, copy, or delete the job. (See “[New/Editing] Dialog Box” on p. 9-5.)

Hint

- If you select a registered job, [Copy] and [Delete] are enabled. Selecting [Copy] displays the following dialog box. Specify the job number to copy to and job title, and click the [OK] button to copy the job to the specified job number.

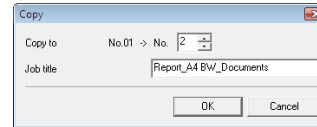

- Selecting [Delete] displays a confirmation message.
- The items of the [Editing] menu are also displayed in a submenu when you right-click a job.

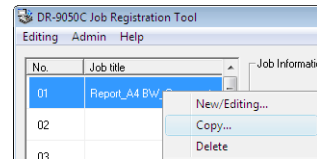

[Admin] Menu

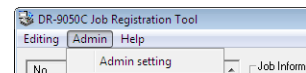

Open the [Admin] dialog box to configure settings for monitoring the storage folder for images and backing up job data. (See “[Admin] Dialog Box” on p. 9-8.)

[Help] Menu

Display the help and version of the Job Registration Tool.

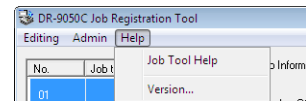

Job List

Displays the job numbers (01 to 99) and job titles.

Job Information

Displays the information for the job selected in the job list.

[Close] Button

Ends the Job Registration Tool.

3. Settings Dialog Boxes

The settings dialog boxes of the Job Registration Tool include the [New/Editing] dialog box and [Admin] dialog box. For details, see the description of each dialog box.



Hint

See “About the Job Function” on p. 3-14 for the procedure for executing jobs registered by the Job Registration Tool.

[New/Editing] Dialog Box

In the [New/Editing] dialog box, you can register new jobs and edit registered jobs.

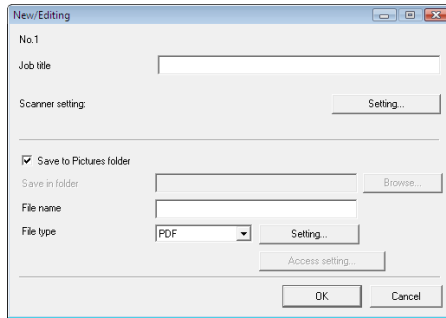

■ Opening the [New/Editing] Dialog Box

Double-click a job number displayed in the job list to open the [New/Editing] dialog box.



Hint

The [New/Editing] dialog box can also be opened in the following ways.

- Right-click the job number you want to register and click [New/Editing] in the submenu.

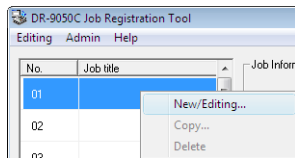

- Select the job number you want to register and click [New/Editing] in the [Editing] menu.

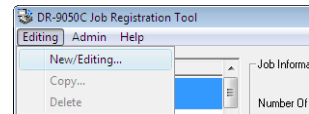

■ [New/Editing] Dialog Box Settings

You can configure the following settings in the [New/Editing] dialog box.

No.

Displays the selected job number.

Job title

Enter the job title to display on the display panel of the control panel.



Hint

- A maximum of 29 alphanumeric single-byte characters can be entered for a job title.
- If special characters with accent marks as used in European languages are used in the job title, the accent marks are not displayed on the display panel.

Scanner Settings

Press the [Setting] button to configure scanner settings.

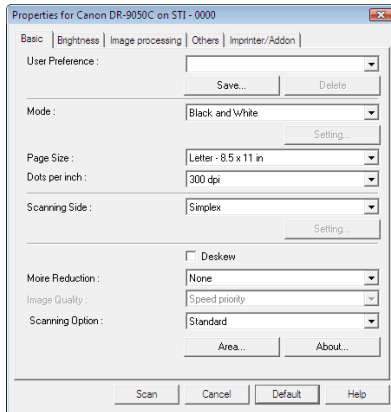

[Save to Pictures folder] Check Box

Select this check box to save image files to the Pictures folder of the user logged in to Windows.

Hint

- The name displayed for Pictures differs depending on the name of the folder in the Windows you are using. Example: My Pictures, Pictures
- When this check box is not selected, the [Save in folder] and [Access setting] buttons are enabled.

Save in folder

When the [Save to Pictures folder] check box is not selected, this is enabled for you to specify any name for the folder in which to save scanned images.

File name

Enter a name for the files to save.

Hint

- File names may consist of up to 32 alphanumeric characters.
- A time stamp is appended to the file name indicating the time of scanning.

File type

Enter the file format for saved files.

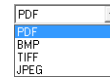

When scanning multi-page documents, image files are created as follows according to the selected file format:

PDF: All pages are saved in a single image file.

BMP: Each page is saved in a separate image file.

TIFF: You can select the method for saving multiple pages in the [TIFF Setting] dialog box displayed by clicking the [Setting] button.

JPEG: Each page is saved in a separate image file.

Hint

- Selecting [TIFF] or [PDF] enables the [Setting] button.
- When a mode other than [256-level Gray] or [24-bit Color] is selected, an error is displayed if [JPEG] is selected when you click the [OK] button. If the error appears, change the file format or scanner mode.

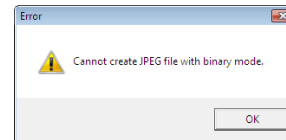

[Setting] Button

This button is enabled to display the corresponding setting dialog box when the [TIFF] or [PDF] file format is selected.

[Access setting] Button

This button is enabled when the [Save to Pictures folder] check box is not selected, and allows you to enter the user name and password required to access the shared network folder specified for [Save in folder].

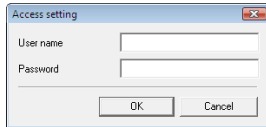

! IMPORTANT

Access to shared network folders may be restricted to users with certain access permission. In this case, users cannot access the shared folder without entering the correct user name and password. Confirm the access rights for the shared network folder with the network administrator, then enter the user name and password.

■ [PDF setting] Dialog Box Settings

You can configure the following settings in the [PDF setting] dialog box.

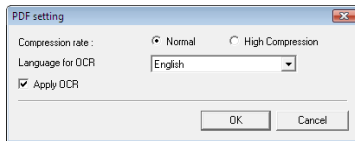

Compression rate

Select the compression rate for PDF files from [Normal] and [High Compression].

💡 Hint

- Select [Normal] to save files with normal compression.
- Select [High Compression] to save files with high compression. Although file size is reduced, image quality may be slightly degraded.

! IMPORTANT

The Compression rate setting is enabled when the scanner is set to [256-level Gray] or [24-bit Color] mode. When [Black and White] or [Error Diffusion] binary image scanning mode is selected, file size depends on the content of the scanned document.

Language for OCR

When the [Apply OCR] check box is selected, the target language for OCR can be selected in the list box.

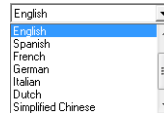

💡 Hint

Characters within document images are recognized as text and saved as appended text data in PDF (*.pdf) files.

■ [TIFF setting] Dialog Box Settings

You can configure the following settings in the [TIFF setting] dialog box.

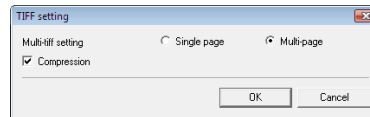

Multi-tiff setting

Select the method for saving image files when scanning multi-page documents.

💡 Hint

- Select [Single page] to save each page as one image file.
- Select [Multi-pages] to save all pages as one image file.

[Compression] Check Box

Select this check box to compress images saved to files. Black and white (binary) images are compressed in CCITT Group 4 format, and grayscale and color images in JPEG format. When this check box is not selected, the saved files are much larger.

Hint

- CCITT Group 4 is a compression format designed for data communications (such as with fax devices) of black and white (binary) images.
- JPEG is a compression format for saving grayscale and color images. When the [Compression] check box is selected, a standard level of JPEG compression is applied.

IMPORTANT

If your application program does not support the above compression formats, you may be unable to open scanned image files. In this case disable [Compression] when scanning.

[Admin] Dialog Box

The [Admin] dialog box allows you to configure settings for monitoring the storage folder for images and backing up job data.

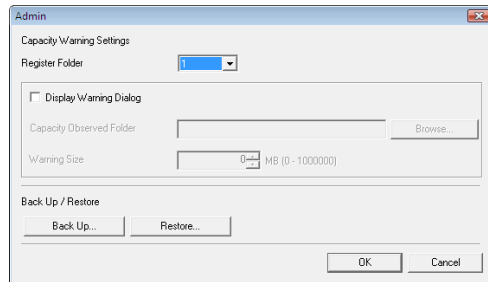

Opening the [Admin] Dialog Box

Click [Admin setting] in the [Admin] menu to open the [Admin] dialog box.

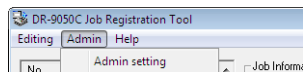

Capacity Warning Settings

The Capacity Warning Settings allow you to specify in advance the folder for saving image files, and the space to be available for saving files. If the space required to save a file would exceed the specified Warning Size when starting to scan or while scanning, a warning message appears.

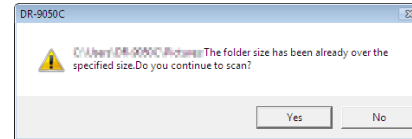

Register Folder

A warning size (capacity) can be specified for up to five folders, with the number (1 to 5) of the folder to be selected registered by [Register Folder].



[Display Warning Dialog] Check Box

Select this check box when you want to limit space available in a destination folder, by registering the folder number and specifying a warning size.

[Capacity Observed Folder]

Specify a folder for which to limit space available.

[Warning Size]

Enter the maximum total size for all files saved to the specified folder.

! IMPORTANT

- When saving to removable storage media such as CD-R, specify the maximum capacity of the media.
- When folder monitoring ([Display Warning Dialog]) is enabled, a warning message appears when starting to scan if the total size of the files in the specified folder exceeds the specified limit.
- If a warning message appears, follow the instructions in the message to either continue scanning or change the save destination first.

■ Job Back Up Function

You can use this function to back up the registered jobs when the same job is to be executed in a different environment, such as occurs when multiple users log on to Windows or when multiple scanners are used.

[Back Up] Button

Writes a backup file (*.reg) of registered job data to the specified folder.

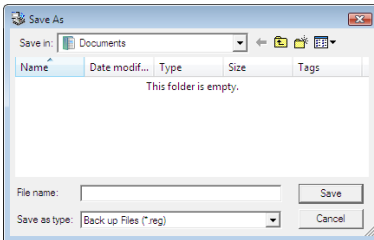
**[Restore] Button**

Restores the job data from a stored backup file (*.reg).

💡 Hint

If the currently registered job number is the same as that of an existing backup file, the existing backup file is overwritten by the registered job.

Chapter 10 Practical Examples

1. About Basic Condition Settings	10-2
Confirming the Basic Conditions for Scanning.....	10-2
2. Practical Examples	10-4
Scanning Documents of Unregistered	
Page Sizes	10-4
Specifying the Scanning Area	10-5
Configuring Scanner Settings According to the	
Purpose.....	10-6
Registering Your Settings	10-11

1. About Basic Condition Settings

This chapter provides an overview of the basic setting items that are the minimum requirements when configuring the scanner settings. For details on settings, see [Chapter 8 “ISIS/TWAIN Driver Settings Dialog Box”](#).

Confirming the Basic Conditions for Scanning

When you scan a document, be sure to confirm the basic conditions [Mode], [Page Size], [Dots per inch], and [Scanning Side] on the [Basic] tab sheet.

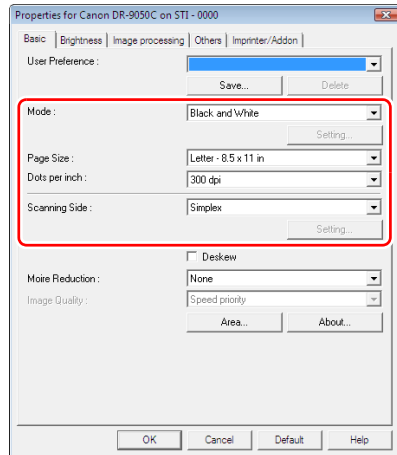

Mode

Select the scanning mode.

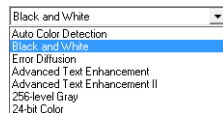

Hint

- [Advanced Text Enhancement] removes or processes the background color and background surrounding text to enhance the text for easy reading.
- [Auto Color Detection] saves color images for color documents, and black and white images for black and white documents.

Page Size

Select the page size of the document to be scanned.

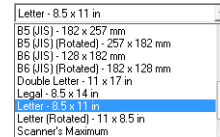

Hint

If [Auto-detection] is selected, the edges of the document are detected and images that match the size of the document are saved.

Dots per inch

Select the scanning resolution.

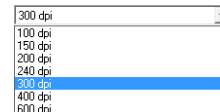

Hint

Higher resolutions provide clearer images, but produce larger files.

Scanning Side

Select which page side(s) to scan.



Hint

- If the scanning side is set to [Skip blank page], the images of blank pages are deleted when the images are saved.
- [Folio] recombines the front and back images scanned from both sides of the document into a single image.

2. Practical Examples

This section provides an overview of which items to set according to the purpose when configuring the scanning settings. For details on settings, see [Chapter 8 “ISIS/TWAIN Driver Settings Dialog Box”](#).

Scanning Documents of Unregistered Page Sizes

Configuring the following settings allows you to scan a document of an unregistered page size.

■ Scanning documents longer than 17.01" (432 mm) (Long Document Mode)

When you want to scan a document that is longer than 17.01" (432 mm), you can enable [Long Document] in the scanner settings and set the page size setting to [Auto-detection] in order to scan documents up to 118.11" (3 m) long.

1. In the User Mode, set [Long Document] of the scanner settings to [ON1] or [ON2]. (See “Long Document Mode Setting” on p. 3-4.)

```

L o n g   D o c u m e n t
   O N 2   [ O N 1 ]   O F F
  
```

2. Set the page size to [Auto-detection] and scan the document.

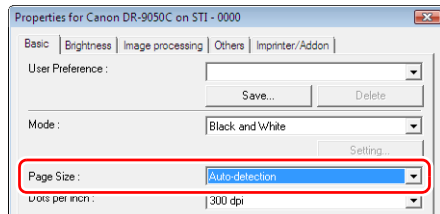

! IMPORTANT

- When scanning a long document, load and scan the pages of the document one at a time.
- When scanning with the Long Document Mode set to [ON1], if the scan is performed with the scanning mode set to color and the image quality set to [Image quality priority], the image may be lost. If this occurs, scan by using black and white or reducing the image quality.
- When scanning with the Long Document Mode set to [ON2], if the scan is performed at 400/600 dpi or the scan is performed with the scanning mode set to color and the scanning side set to [Duplex], the image may be lost. If this occurs, scan by reducing the resolution, using black and white, or setting the scanning side to [Simplex].
- When scanning using Long Document Mode, [High-Quality Moire Reduction], [Deskew], or document orientation of [90 degrees] or [270 degrees] cannot be used.

■ Scanning documents wider than the feeder inlet (Folio Scan)

When you want to scan a document that is wider than the feeder inlet, you can scan the document if you fold the document into two, load it into the feed tray, and set the scanning side setting to [Folio]. (See p. 4-6.)

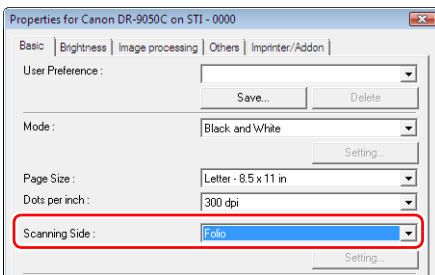
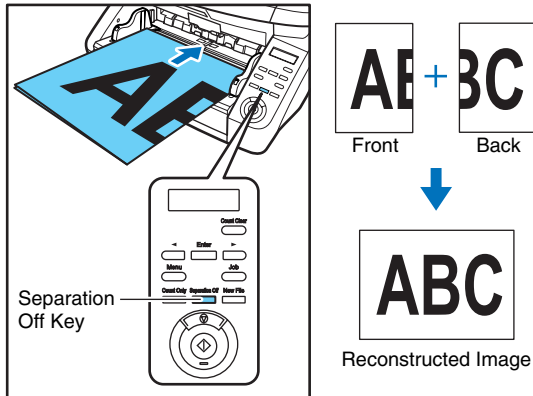

Hint

Folio Scan supports up to A1-size (23.4" × 33.1" (594 × 841 mm)) documents when used together with the Long Document Mode.

■ Registering of unregistered non-standard page sizes

You can register a non-standard page size that has not been registered as a page size by naming and registering it as a custom page size in the [Page Size] setting of the Scan Area dialog box, which is opened from the [Area] button on the [Basic] tab sheet. (See p. 8-13.)

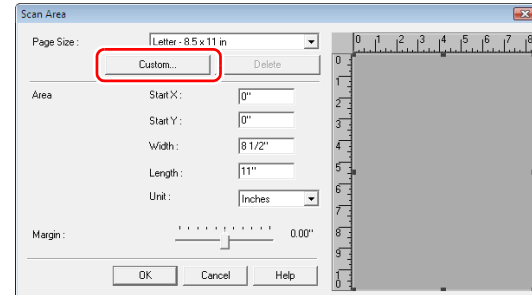

Specifying the Scanning Area

Configure the following settings when you want to specify the area of the document to scan.

■ Specifying an area

Specify the area of the document to scan in the Scan Area dialog box. (See p. 8-12.)

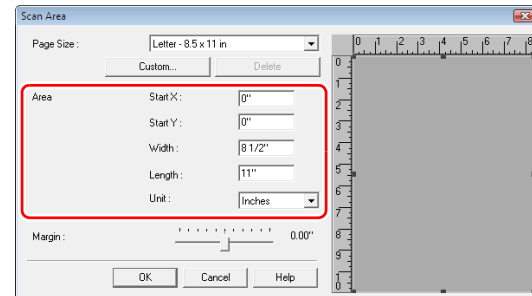

Hint

- With the TWAIN driver, load the document you want to specify the area of and press the [Preview] button to scan the document and display the preview image in the Area panel. You can then specify the area from the displayed preview image.

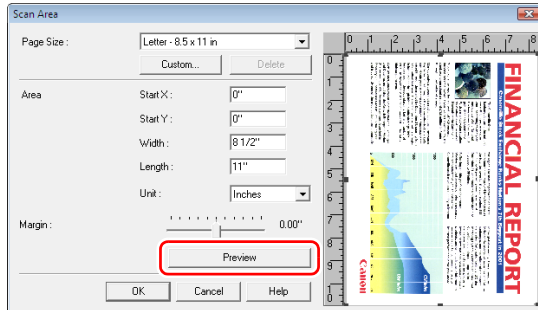

- With CapturePerfect 3.0, the last scanned image appears in the preview window. Scan the document you want to set the area of with [Scan Single Page] in order to display the image in the preview window.

■ Adjusting the margins

When the document is deskewed and edges are missing from the image or black borders are created around the image, adjust the scanning area by setting the margins. (See p. 8-13.)

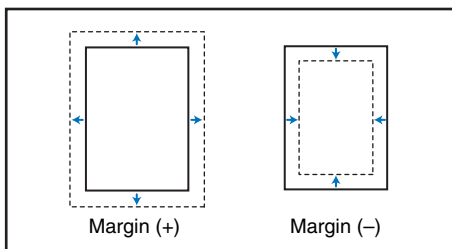

Configuring Scanner Settings According to the Purpose

Set the scanning conditions according to the scanning purpose.

■ When you do not want to scan colored lines and characters

Select the color (red, blue, or green) to be ignored (dropped out) in [Color drop-out] on the [Image processing] tab sheet, and that color will be not be scanned. (See p. 8-18.)

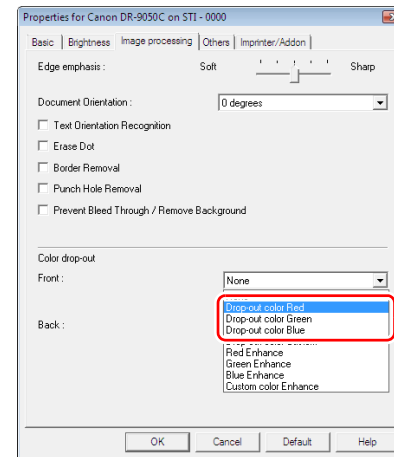

■ When you want to enhance a particular color

Select the color (red, blue, or green) to be enhanced in [Color drop-out] on the [Image processing] tab sheet, and that color will be enhanced.

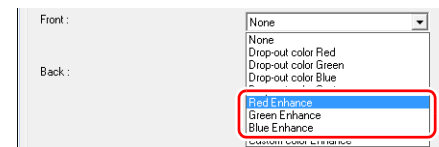

■ **When you want to skip or enhance intermediate colors**

Select an intermediate color in [Color drop-out] on the [Image processing] tab sheet.

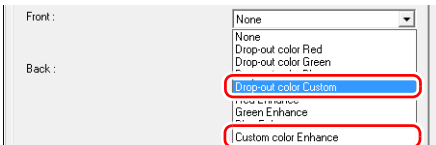

Click the [Setting] button to display the Color Settings dialog box, and then you can specify the color range of the intermediate colors to ignore (drop out) or enhance.

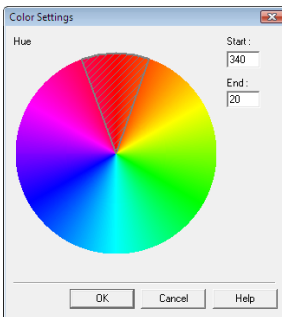

■ **When you want to prevent the bleed-through of text and other items from the back side of thin pages, or remove the background from scanned images**

Select [Prevent Bleed-Through / Remove Background] on the [Image processing] tab sheet. The bleed-through on thin pages and background are removed from scanned images. (See p. 8-17.)

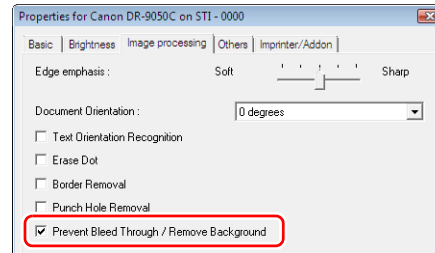

■ **When you want to enhance contours in images**

Adjust the [Edge Emphasis] setting on the [Image processing] tab sheet. (See p. 8-16.)

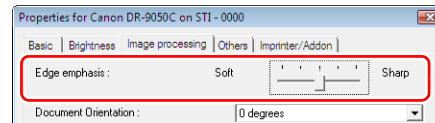

- **When you want to change the brightness on the front and back sides to scan a document with front and back sides of different densities**

Set the brightness of the back side on the [Brightness] tab sheet. (See p. 8-15.)

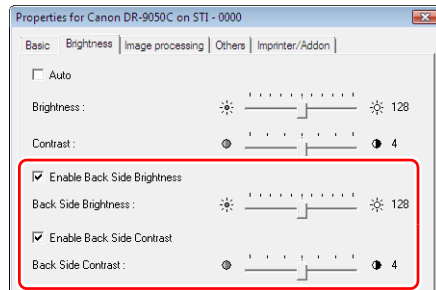

Hint

The brightness of the back side cannot be changed when you are using advanced text enhancement for scanning.

- **When you want to eliminate black borders around scanned images**

Select [Border Removal] on the [Image processing] tab sheet. The black borders created around scanned images are removed.

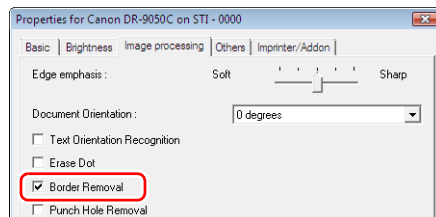

- **When you want to reduce the moire patterns that appear when color photos in magazines and other documents are scanned at low resolutions**

Setting [Moire Reduction] on the [Basic] tab sheet allows you to reduce the moire patterns that are generated when color photos are scanned at low resolutions. (See p. 8-10.)

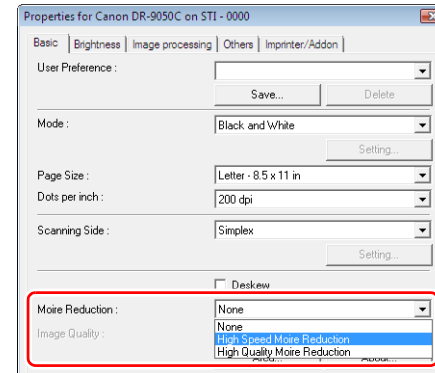

Hint

Moire reduction is enabled when the resolution is 300 dpi or less, and [High-Quality Moire Reduction] is displayed when the resolution is 240 dpi or less.

- **When you want to save black and white images and color images separately when scanning a mixture of black and white documents and color documents**

When documents are scanned while the mode is set to [Auto Color Detection] on the [Basic] tab sheet, the document colors are detected and black and white images and color images are saved separately. (See p. 8-7.)

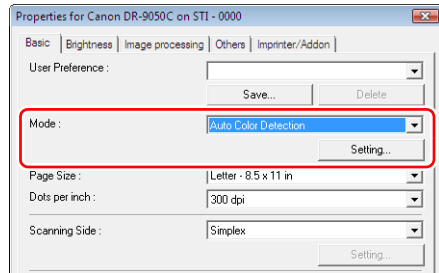

Hint

Selecting [Auto Color Detection] enables the [Setting] button, and you can configure settings for judging whether documents are color, and select the mode for when documents are judged to be black and white. (See p. 8-11.)

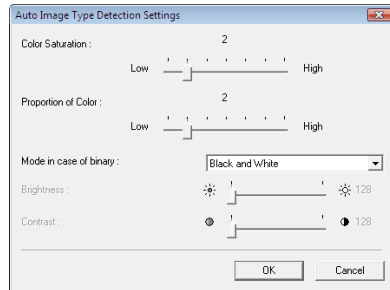

- **When you want to reverse black and white in scanned images (TWAIN driver only)**

Select [Reverse Image] on the [Image processing] tab sheet. This outputs scanned images with black and white reversed. (See p. 8-17.)

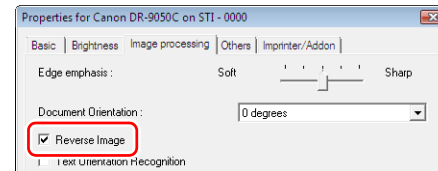

Hint

The ISIS driver does not have a function for reversing black and white.

- **When you want to enhance text that is difficult to read because of factors such as the background of the scanned document**

Select [Advanced Text Enhancement] as the mode on the [Basic] tab sheet. The background behind the text is removed or processed so that the text is emphasized for better legibility. (See p. 8-8.)

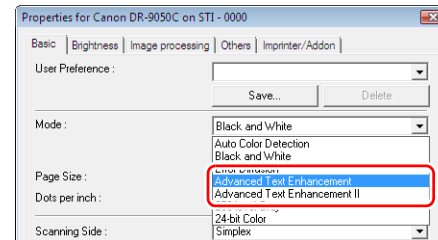

Hint

[Advanced Text Enhancement II] is displayed when the resolution is 300 dpi or less.

■ **When you want to remove the black spots from scanned images when scanning documents with punch holes**

Select [Punch Hole Removal] on the [Image processing] tab sheet. The black spots from punch holes in documents are removed from scanned images. (See p. 8-17.)

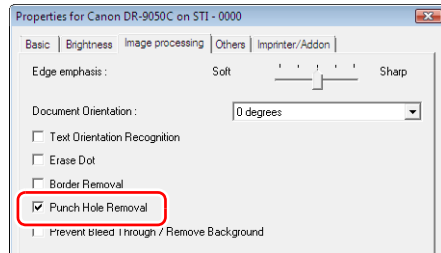

■ **When you want to match the orientation of images to the text when scanning a mixture of pages with different text orientations**

Select [Text Orientation Recognition] on the [Image processing] tab sheet. (See p. 8-17.)

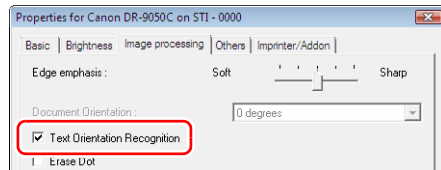

The text orientation on each page is detected, and the scanned image is rotated in 90-degree increments to correct the orientation.

Text Orientation	↑ ABC	↑ ABC	↑ ABC	↑ ABC
Output Image	ABC	ABC	ABC	ABC



Hint

When [Text Orientation Recognition] is selected, image rotation is disabled.

■ **When you want to rotate the images of a document loaded horizontally to correct the orientation**

Specify the rotation angle with [Document Orientation] on the [Image processing] tab sheet. (See p. 8-17.)

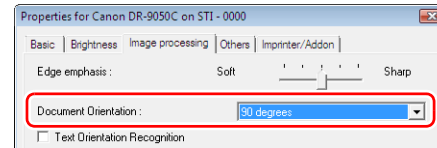

Hint

Images are rotated as follows according to the orientation of the loaded document and the selected angle.

Feeder Document: Face Up	↑ ABC	↑ ABC	↑ ABC	↑ ABC
Document Orientation (Clockwise)	0 degrees	90 degrees	180 degrees	270 degrees
Output Image	ABC	ABC	ABC	ABC

■ When you want to delete the images of the blank pages in two-sided documents

If you set the scanning side setting to [Skip blank page] on the [Basic] tab sheet, the images of blank pages in the document are deleted. (See p. 8-9.)

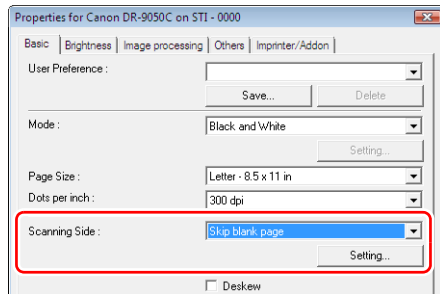

Hint

If [Skip blank page] is selected, the [Setting] button is enabled, and you can adjust the level for judging whether pages are blank.

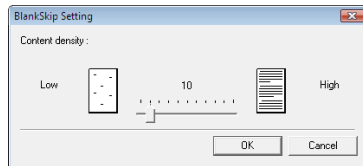

Registering Your Settings

You can register the scanning conditions so that you can use them next time.

■ Registering scanning conditions

Name and register the scanning conditions in [User Preference] on the [Basic] tab sheet. When you want to use the registered scanning conditions, select the registered name to apply the registered scanning conditions.

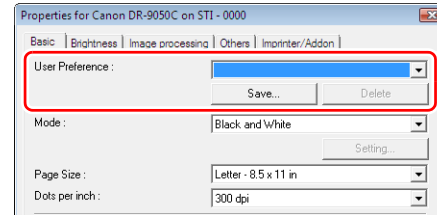



CANON ELECTRONICS INC.

1248, SHIMOKAGEMORI, CHICHIBU-SHI, SAITAMA 369-1892, JAPAN

CANON U.S.A. INC.

ONE CANON PLAZA, LAKE SUCCESS, N.Y. 11042, U.S.A.

CANON CANADA INC.

6390 DIXIE ROAD, MISSISSAUGA, ONTARIO L5T 1P7, CANADA

CANON EUROPA N.V.

BOVENKERKERWEG 59-61, P.O.BOX 2262, 1180 EG AMSTELVEEN, THE NETHERLANDS

CANON LATIN AMERICA, INC.

703 WATERFORD WAY, SUITE 400 MIAMI, FLORIDA 33126, U.S.A.

CANON AUSTRALIA PTY. LTD.

1 THOMAS HOLT DRIVE, NORTH RYDE, SYDNEY. N.S.W, 2113. AUSTRALIA

CANON SINGAPORE PTE. LTD.

1 HARBOUR FRONT AVENUE #04-01, KEPPEL BAY TOWER, SINGAPORE 098632

CANON HONGKONG COMPANY LTD.

19TH FLOOR, THE METROPOLIS TOWER, 10 METROPOLIS DRIVE, HUNGHOM, KOWLOON, HONG KONG.